

**Audi A4 Sedan (8EC) + A4 Avant (8ED) 2005- / A4 Cabrio (8HE) 2006-
Audi A3 (8P1) 2003- + A3 Sportback (8PA) 2005- / A3 Cabrio (8P7) 2008-
Seat Exeo (3R) 2009- / Seat Exeo ST (3R5) 2009-**

Partnr.: AU-037-D1

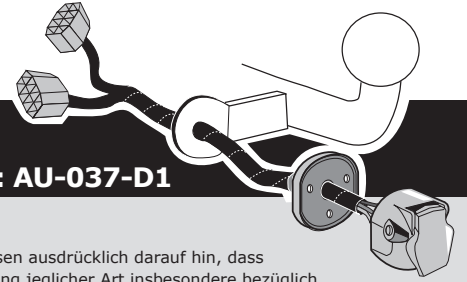

- DE** • Einbauanleitung Elektrosatz Anhängervorrichtung mit 13-P Steckdose It. DIN/ISO Norm 11446. • Wir weisen ausdrücklich darauf hin, dass eine unsachgemäße und nicht in einer Fachwerkstatt durchgeführte Montage einen Verzicht auf Entschädigung jeglicher Art insbesondere bezüglich des Produkthaftpflichtrechts zur Folge hat. • Technische Änderungen vorbehalten. • Widerstand nur gemäß der Tabelle auf dem Anhänger verwenden. • Bei Funktionsproblemen ist die Fehlersuche auf ca. 0,5 Stunden zu begrenzen, kontaktieren Sie die ECS Helpline: customercare@ecs-electronics.nl / 00800 22552327
- FR** • Instructions de montage du faisceau électrique pour crochet d'attelage conforme à la norme DIN/ISO 11446 prise 13-P. • Il est expressément prévu qu' on ne saurait se prévaloir d'un quelconque préjudice contractuel ou réhibitoire si le montage avait été fait en dépit des dites instructions ou dans un garage ne disposant pas des équipements adéquats. • Sous réserve de modifications techniques. • Ne excédez pas la charge maximale, indiquée dans le tableau. • S'il y a des problèmes de fonctionnement, limiter la recherche de défauts à env. 30 minutes et contacter ECS l'Aide en ligne: customercare@ecs-electronics.nl / 00800 22 55 23 27.
- NL** • Montage-handleiding elektrokabelset voor trekhaak met 13-P contactdoos vlg. DIN/ISO norm 11446. • Wij wijzen er met nadruk op, dat ondeskundige en niet door een vakkundige werkplaats uitgevoerde montage tot gevolg heeft dat daardoor ieder recht op schadevergoeding, ook op wettelijke aansprakelijkheid inzake producten, vervalt. • Technische wijzigingen voorbehouden. • Gebruik alleen belasting volgens aansluittabel op het getrokken voertuig. • Bij werkingsproblemen moet de foutencontrole tot ca. 0,5 uur beperkt worden, neem contact op met de ECS Helpline: customercare@ecs-electronics.nl / 00800 22 55 23 27.
- GB** • Fitting instructions electric wiring kit tow bar with 13-P socket up to DIN/ISO Norm 11446. • We would expressly point out that assembly not carried out properly by a competent installer will result in cancellation of any right to damage compensation, in particular those arising by virtue of the product liability act. • Contents of these kits and their fitting manuals are subject to alteration without notice, please ensure that these instructions are read and fully understood before commencing installation. • Do not overload circuits; the maximum loads per connection are detailed in this manual. • In the event of functional problems, troubleshooting must be limited to about 0.5 hours, contact the ECS Helpline: customercare@ecs-electronics.nl / 00800 22 55 23 27.
- ES** • Instrucciones de montaje de kit eléctrico para enganche de remolque con caja de conexiones 13-P según norma DIN/ISO 11446. • El montaje inapropiado y efectuado por personal no cualificado originará la pérdida de todo derecho a indemnización o la expiración de toda responsabilidad civil con respecto al producto. • Nos reservamos el derecho a efectuar modificaciones técnicas. • Utilice sólo cargas de acuerdo a la tabla de conexión del vehículo remolcado. • En caso de tener problemas con su funcionamiento, la búsqueda de errores está limitada a aprox. 0,5 horas, por lo que le recomendamos ponerse en contacto con el servicio de atención telefónica: customercare@ecs-electronics.nl / 00800 22 55 23 27.
- IT** • Istruzioni di montaggio di set di cavi elettrici per gancio da traino con zoccolo a 13-P conforme alla norma DIN/ISO 11446. • Sottolineiamo espressamente che un montaggio inadeguato ed eseguito da un'officina non specializzata ha come conseguenza il decadere di qualsiasi diritto al risarcimento danni, nonché alla responsabilità legale relativa ai prodotti. • Ci si riserva il diritto di apportare modifiche tecniche. • Utilizzare esclusivamente un carico conforme alla tabella degli allacci relativa al veicolo in questione. • In caso di problemi di funzionamento, la ricerca di errori dovrebbe essere limitata a circa 0,5 ore. Contattare il centralino di assistenza per i fasci di cavi: customercare@ecs-electronics.nl / 00800 22 55 23 27.
- SE** • Monteringsanvisningar elkabelsats för dragkrok med 13-P kontaktdosa enligt DIN/ISO norm 11446. • Vi påpekar med eftertryck att all rätt till skadeersättning och all laglig ansvarighet förfaller om monteringen inte har utförts på rätt sätt och av en professionell verkstad. • Tekniska ändringar förbehålles. • Använd endast belastning enligt anslutningstabellen på det dragna fordonet. • Vid funtionsproblem ska felsökningen begränsas till ca 0,5 timme, kontakta reservdels-helpline customercare@ecs-electronics.nl / 00800 22 55 23 27.
- CZ** • Montážní pokyny: souprava pro elektrické propojení tažné tyče s 13-P zásuvkou do normy DIN/ISO 11446. • Výslovně zdůrazňujeme, že jakákoli montáž, která není provedená ve specializované dílně, má za následek odvolání nároků na kompenzaci jakéhokoli druhu, obzvláště vyplývajících ze zákona o odpovědnosti za způsobené škody. • Změny mohou být provedeny bez oznámení. • Používejte pouze při maximálním nabití podle tabulky na tažném vozidle. • Při problémech funkčnosti je třeba vyhledávání chyb omezit na cca 0,5 hodiny, kontaktujte ECS Helpline: customercare@ecs-electronics.nl / 00800 22 55 23 27.
- DK** • Monteringsvejledninger for det elektriske ledningsføringssæt for trækstang med 13-P stikdåse, DIN/ISO, norm 11446. • Vi ønsker at gøre udtrykkeligt opmærksom på atfærkt samling, der ikke er udført af et specialiseret værksted, resulterer i bortfaldelse af kompensationskrav af alle slags, i særdeles krav der måtte opstå omkring det lovpligtige ansvar. • Kan ændres uden varsel. • Brug kun den maksimale belastning, i overensstemmelse med forbindelsestabelen for bugserede køretøjer. • Ved funktionsproblemer skal fejlsøgningen begrænses til ca. 0,5 time, kontakt ECS Helpline: customercare@ecs-electronics.nl / 00800 22 55 23 27.
- FI** • Ohjeet vetokoukun sähkökaapelisarjan asentamiseen, jossa on DIN/ISO 11446 mukainen 13-P liitin. • Korostamme, että kaikki oikeudet vahinkokorvaukseen kuten myös valmistajan laillinen vastuu raukeavat, mikäli asennusta ei ole toteutettu oikealla tavalla eikä ammattitaitoisen asiantuntijan toimesta. • Oikeus tekniisin muutoksiin ilman erillistä huomautusta pidätetään. • Kuormita työvirtapiiriä ainoastaan hinattavan ajoneuvon kytkentäkaavin mukaisesti. • Virrehaku on rajoitettava toiminto-ongelmien esiintyessä noin 0,5 tuntiin, ota yhteys ECS Helpline: customercare@ecs-electronics.nl / 00800 22 55 23 27.
- GR** • Οδηγίες συναρμολόγησης ηλεκτρικού σετ καλωδίων μπάρας ρυμούλκησης με υποδοχή 13-P μέχρι DIN/ISO Κανόνας 11446. • Επισημαίνουμε κατηγορηματικά ότι οποιαδήποτε εσφαλμένη συναρμολόγηση, η οποία δεν έχει πραγματοποιηθεί ειδικό εργαστήριο θα οδηγήσει σε απονοίηση των αξιώσεων επιβολής αποζημιώσεων οποιαδήποτε είδους, ειδικά όσα προκύπτουν από το νόμο ευθύνης προϊόντων. • Μπορεί να τροποποιηθεί χωρίς προηγούμενη ειδοποίηση. • Χρησιμοποιείτε μόνο μέγιστο ηλεκτρικό φορτίο σύμφωνα με τον πίνακα σύνδεσης στο ρυμούλκούμενο όχημα. • Σε περίπτωση προβλημάτων λειτουργίας να περιοριστεί η αναζήτηση σφαλμάτων σε περ. 0,5 δευτ., επικοινωνήστε με τη γραμμή υποστήριξης ECS Helpline: customercare@ecs-electronics.nl / 00800 22 55 23 27.
- NO** • Monteringsanviser elkabelsett for trekkrok med 13-P koblingsboks ifølge DIN/ISO norm 11446. • Vi påpeker ettertrykkelig at all rett til skadeerstatning og rettslig ansvar forfaller dersom monteringen ikke er blitt utført på riktig måte og av et profesjonelt verksted. • Tekniske endringer forbeholdes. • Overskrid ikke grensene anvist i tilkoblingstabellen på tilhengeren eller det tilkoblede kjøretøyet. • Ved funksjonsproblemer må feilsøket begrenses til ca. 0,5 timer, kontakt ECS Helpline: customercare@ecs-electronics.nl / 00800 22 55 23 27.
- PL** • Instrukcje montażu zestawu okablowania elektrycznego dyszla holowniczego z 13-P stykowym gniazdem DIN/ISO 11446. • Chcielibyśmy wyraźnie zaznaczyć, iż wszelki nieprawidłowy montaż, który nie jest wykonywany w specjalistycznym warsztacie pociąga za sobą utratę możliwości dochodzenia wszelkiego typu roszczeń, w szczególności tych wynikających z odpowiedzialności producenta za swój produkt. • Podlega zmianom bez powiadomienia. • Używać tylko takiego maksymalnego obciążenia które wynika z tabliczki połączeń holowanego pojazdu. • W przypadku problemów ograniczyć wyszukiwanie błędów do ok. 0,5 godziny, skontaktować się z linią serwisową customercare@ecs-electronics.nl / 00800 22 55 23 27.

Einzelteilliste

Liste de pièces

Onderdelenlijst

Part list

Lista de componentes

Elenco componenti

Dellista

Seznam dílů

Del-liste

Osaluettelo

Κατάλογος εξαρτημάτων

Delliste

Lista części

(DE)

(FR)

(NL)

(GB)

(ES)

(IT)

(SE)

(CZ)

(DK)

(FI)

(GR)

(NO)

(PL)

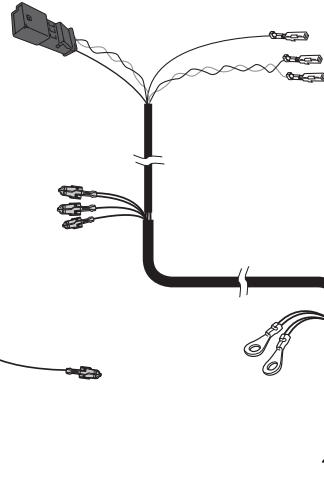
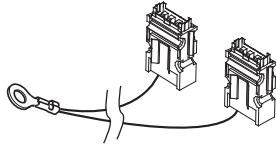
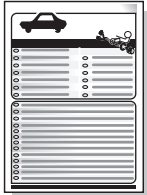
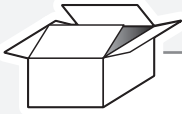

*
OPTION P.D.C.

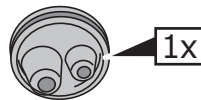
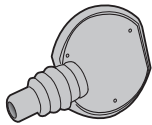
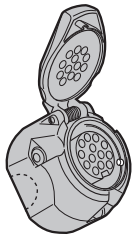
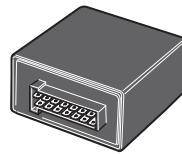

Option! *



For not OEM P.D.C. System
use the: VW-083-ZZ

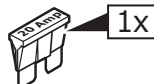
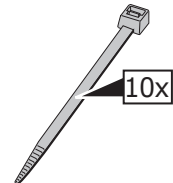
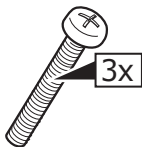

COLOR TABLE

	(DE)	(FR)	(GB)	(NL)	(ES)	(IT)	(SE)	(CZ)	(DK)	(FI)	(GR)	(NO)	(PL)
BU	Blau	Bleu	Blue	Blauw	Azul	Blu	Blå	Modrá	Blå	Sininen	Μπλε	Blå	Niebieska
BK	Schwarz	Noir	Black	Zwart	Negro	Nero	Svart	Černá	Sort	Musta	Μαύο	Sort	Czarna
BN	Braun	Marron	Brown	Bruin	Marrón	Marrone	Brun	Hnědá	Brun	Ruskea	Καφέ	Brun	Brązowa
GN	Grün	Vert	Green	Groen	Verde	Verde	Grön	Zelená	Grøn	Vihreä	Πράσινο	Grønn	Zielona
GY	Grau	Gris	Grey	Grijs	Gris	Grigio	Grå	Šeda	Grå	Harmaa	Γκρι	Grå	Szara
OG	Orange	Orange	Orange	Oranje	Naranja	Arancione	Orange	Oranžová	Orange	Oransi	Πορτοκάλι	Orange	Pomarańczowa
RD	Rot	Rouge	Red	Rood	Rojo	Rosso	Röd	Červená	Rød	Punainen	Κόκκινο	Rød	Czerwona
WH	Weiß	Blanc	White	Wit	Blanco	Bianco	Vit	Bílá	Hvid	Valkoinen	Λευκό	Hvit	Biała
YE	Gelb	Jaune	Yellow	Geel	Amarillo	Giallo	Gul	Žlutá	Gul	Keltainen	Κίτρινο	Gul	Żółta
PK	Rosa	Rose	Pink	Rosé	Rosa	Rosa	Rosa	Růžová	Rosa	Rosa	Ροζ	Rosa	Różowa
PE	Purpur	Pourpre	Purple	Paars	Púrpura	Rosso porpora	Purper	Purpurov	Purper	Purppura	Πορφυρό	Purper	Purpurowa
DL	Dunkelblau	Bleu foncé	Dark blue	Donkerblauw	Azul oscuro	Blu scuro	Mörkblå	Tmavomodrá	Mørkeblå	Tummansininen	Σκούρο μπλε	Mørkeblå	Granatowa
DG	Dunkelgrün	Vert foncé	Dark green	Donkergroen	Verde oscuro	Verde scuro	Mörkgrön	Tmavozelená	Mørkegrøn	Tummanvihreä	Σκούρο πράσινο	Mørkegrønn	Ciemnozielona
LB	Hellblau	Bleu clair	Light blue	Lichtblauw	Azul claro	Blu chiaro	Ljusblå	Bleděmodrá	Lyseblå	Vaaleansininen	Ανοικτό μπλε	Lyseblå	Jasnoniebieska
LG	Hellgrün	Vert clair	Light green	Lichtgroen	Verde claro	Verde chiaro	Ljusgrön	Světlezelená	Lysegrøn	Vaaleanvihreä	Ανοικτό πράσινο	Lysegrønn	Jasnozielona
NL	Naturfarben	Nature	Natural colour	Naturel	Color natural	Colori naturali	Naturfärger	Přírodní	Naturfarvet	Luonnonväri	Φυσικά χρώματα	Naturfarger	Barwy
SB	Himmelblau	Bleu ciel	Sky blue	Hemelsblauw	Azul cielo	Celeste	Himmelsblå	Blankytná	Himmelblå	Taivaansininen	Γαλάζιο	Himmelblå	Błękitna
T	Gelbbraun	Marron-jaune	Yellow brown	Geelbruin	Amarillo-marrón	Giallomarrone	Gulbrun	Žlutohnědá	Gulbrun	Keltaisenruskea	Κίτρινοκαφέ	Gulbrun	Żółtobrazowa
VT	Violett	Violet	Violet	Violet	Violeta	Viola	Violett	Fialová	Violet	Violetti	Μοβ	Fiolett	Fioletowa

1

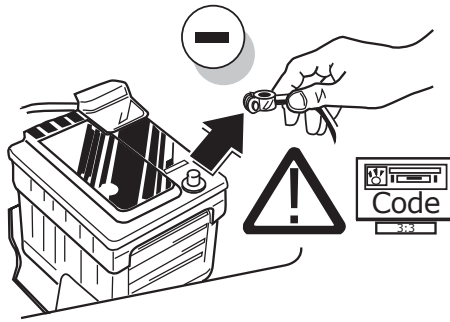

A4 Sedan / A4 Cabrio / Exeo

2

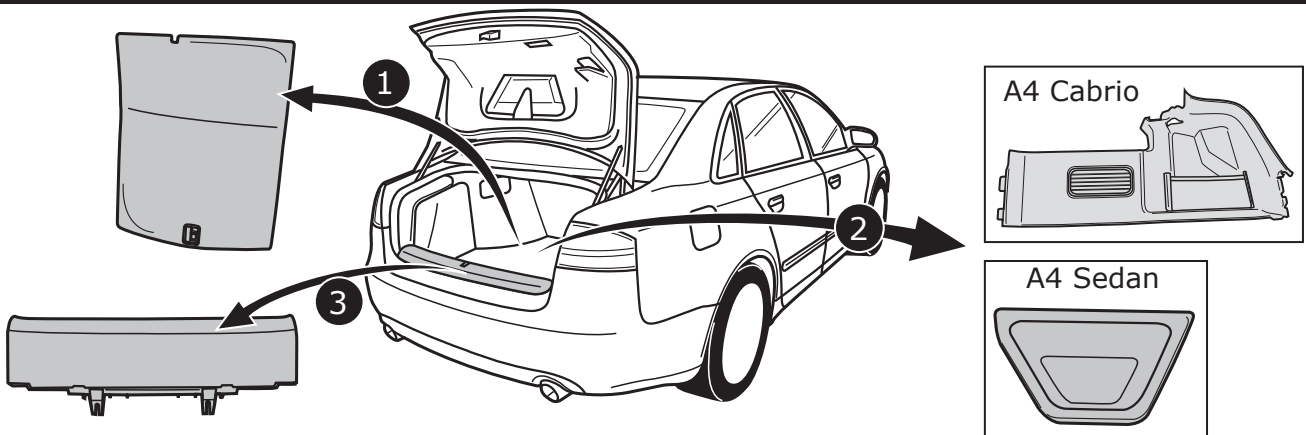

3

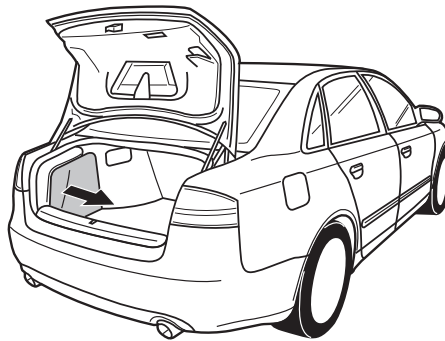

A4 Avant / Exeo ST

4

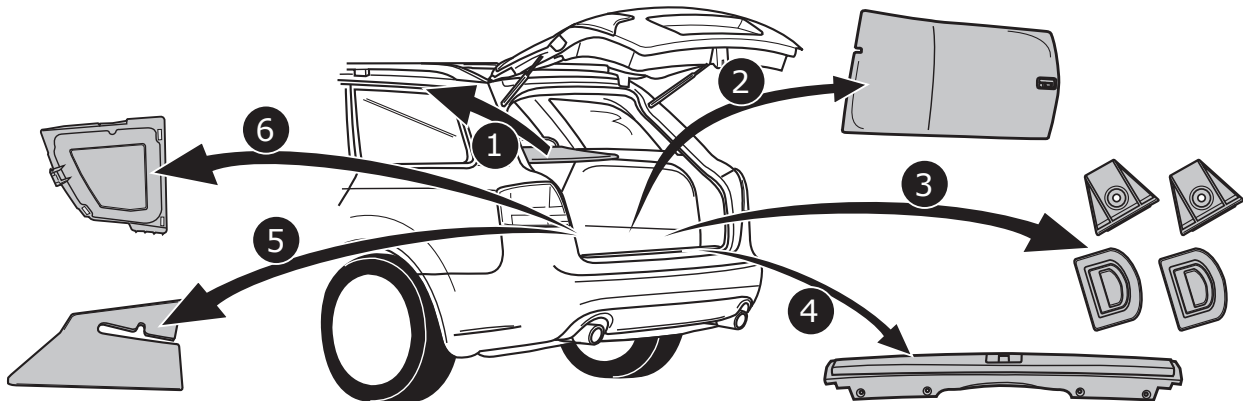

A4 Avant / Exeo ST

5

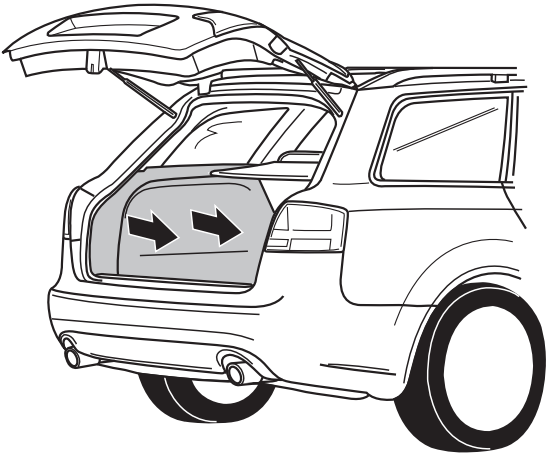

A3

6

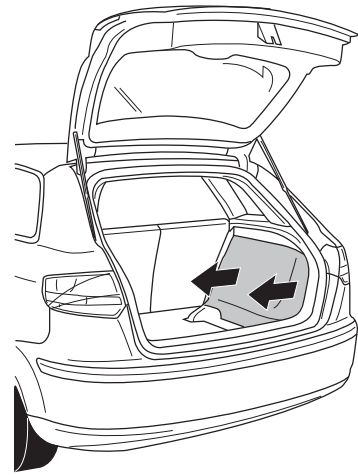

A3 / A3 Cabrio / A3 Sportback

7

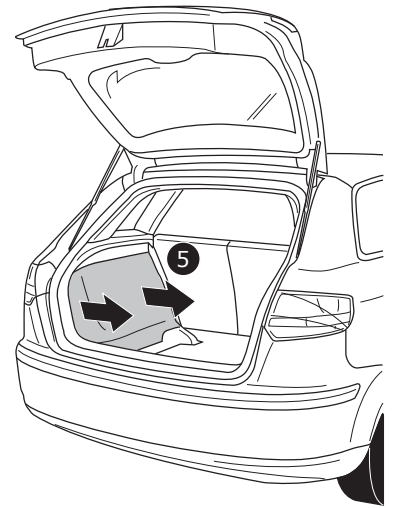
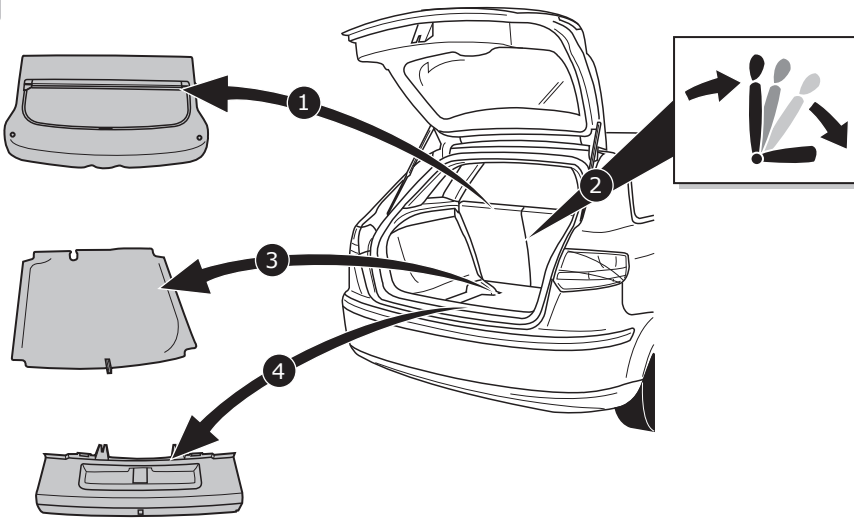

A4 Sedan / A4 Cabrio / A4 Avant / A3 / A3 Cabrio / A3 Sportback / Exeo / Exeo ST

INFO

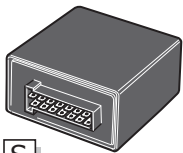

S



T



Q

R



H

I

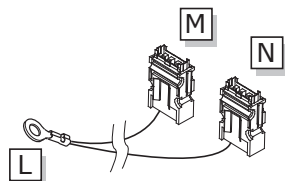

L

M

N



E

F

G

D



B

A

-31

OPTION P.D.C.

X

A4 Sedan / A4 Cabrio / Exeo

ROUTING

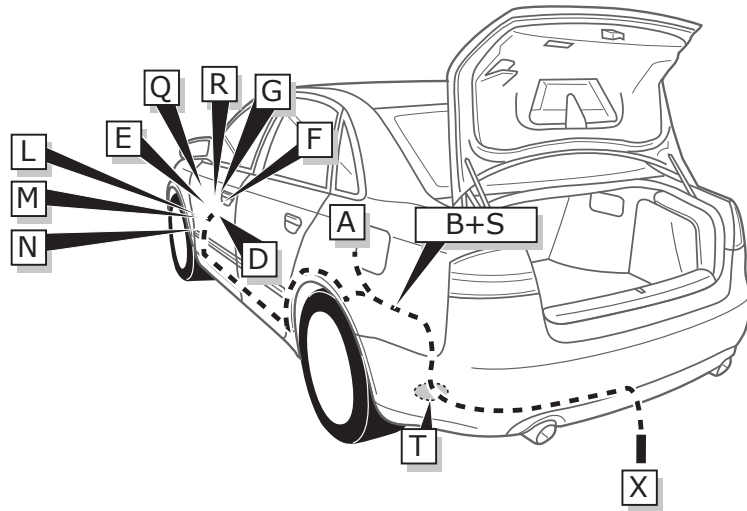

A4 Avant / Exeo ST

ROUTING

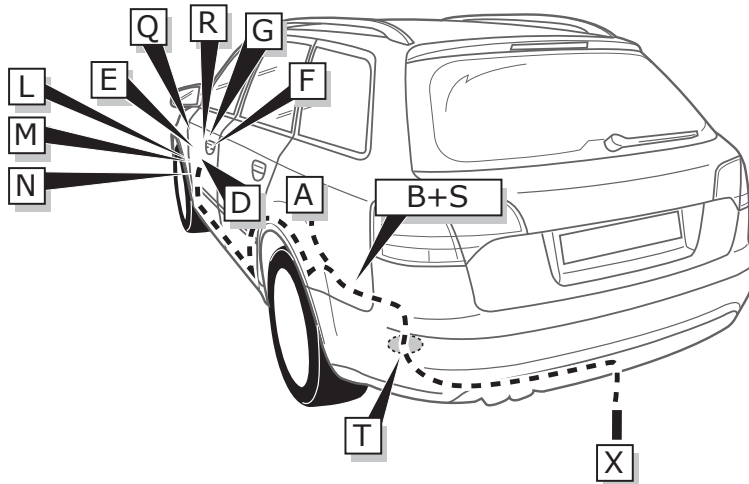

A3

ROUTING

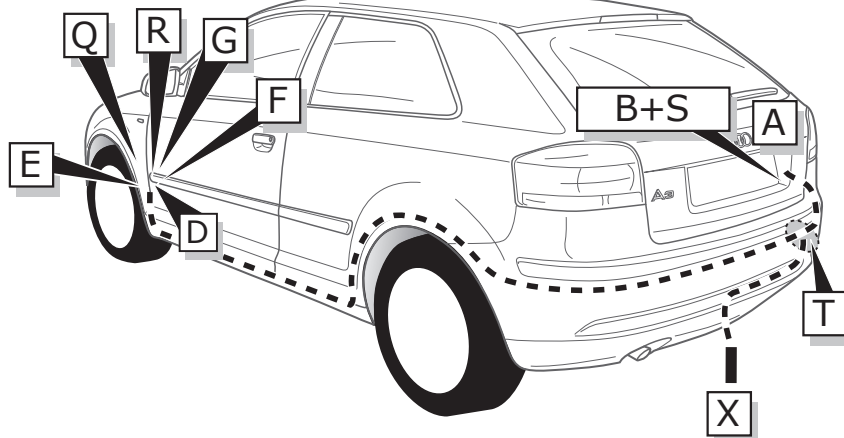

A3 Sportback

ROUTING

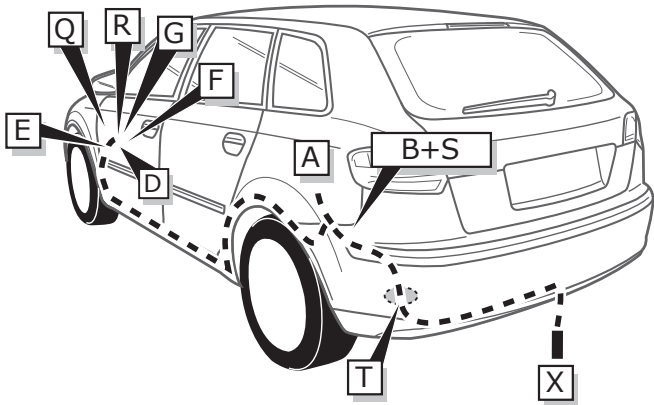

A3 Cabrio

ROUTING

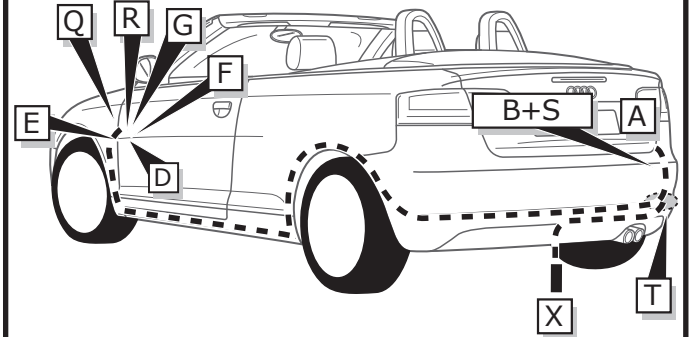

A4 Sedan / A4 Cabrio / A4 Avant / A3 Sportback / Exeo / Exeo ST

8

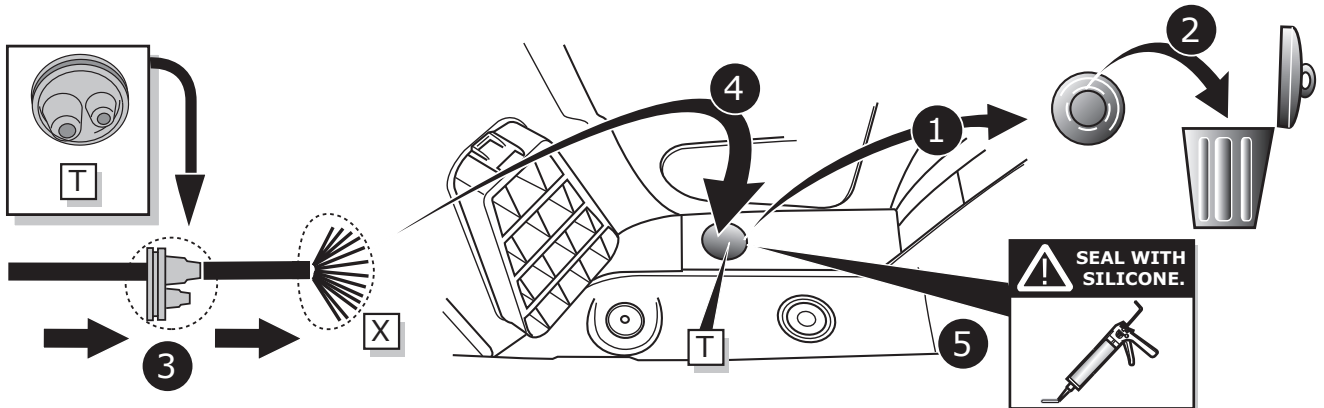

A3 / A3 Cabrio

9

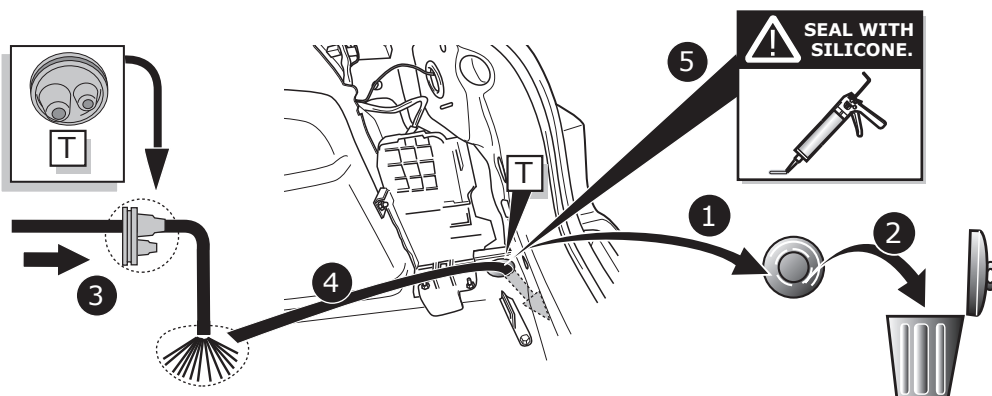

A

Option 1

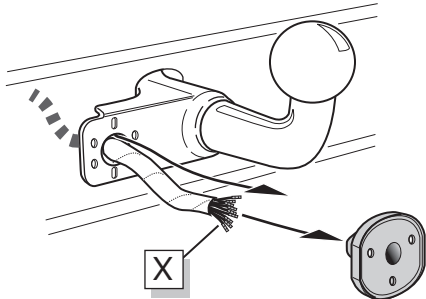

Option 2

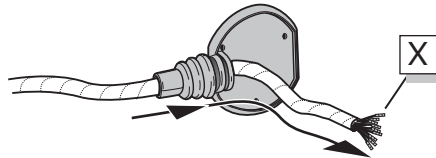

Option 3

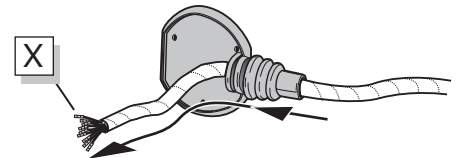

INFO

- (DE) Anschluss Steckdose
- (FR) Connection de la prise
- (NL) Contactdoos aansluiting
- (GB) Socket connection
- (ES) Conexión de la caja de enchufe
- (IT) Allaccio zoccolo
- (SE) Anslutning kontaktdosa
- (CZ) Objímkový konektor
- (DK) Stikdåse forbindelse
- (FI) Pistorasia liitäntä
- (GR) Υποδοχή σύνδεσης
- (NO) Tilkobling koblingsboks
- (PL) Połączenie przez gniazdo



Pag. 24

B

Option 1

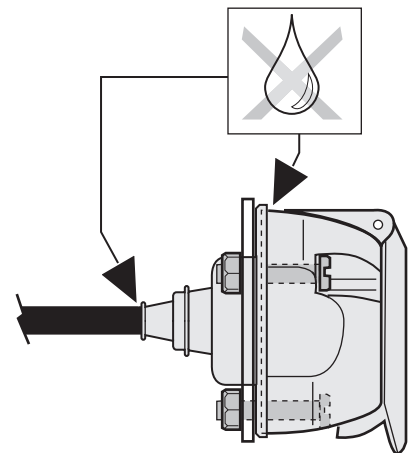
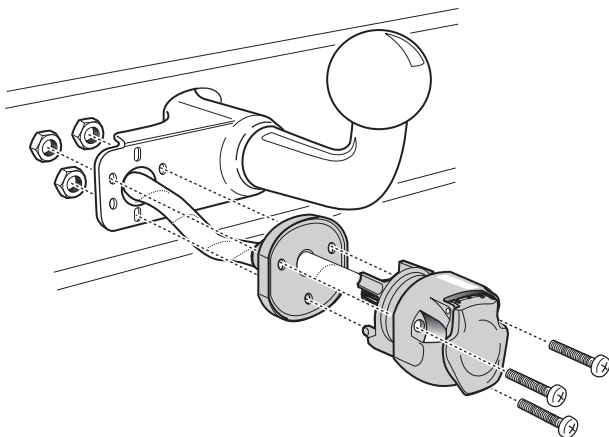

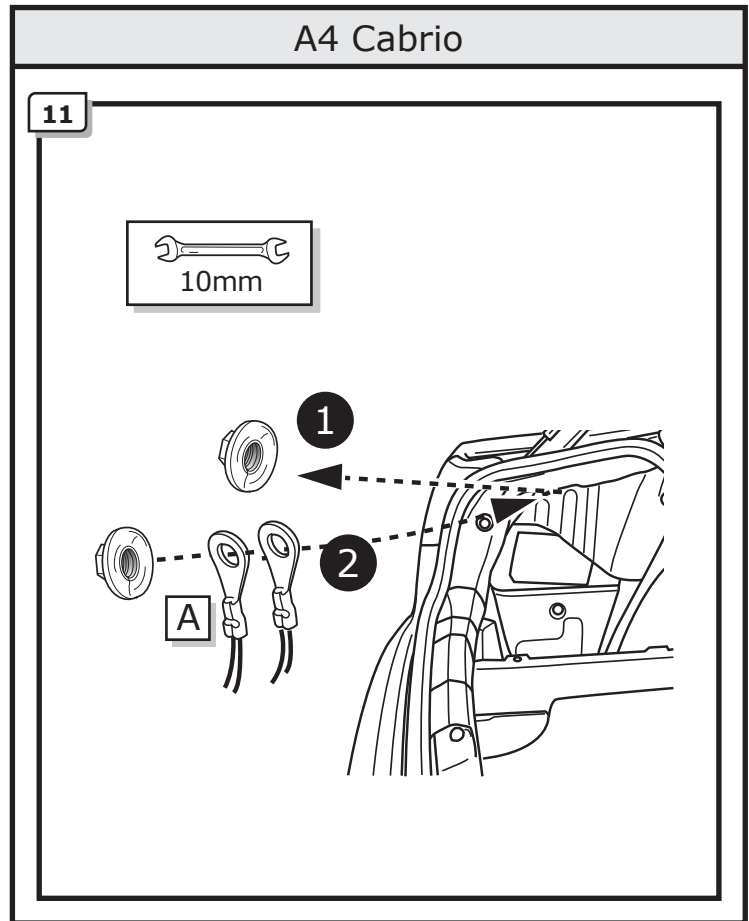
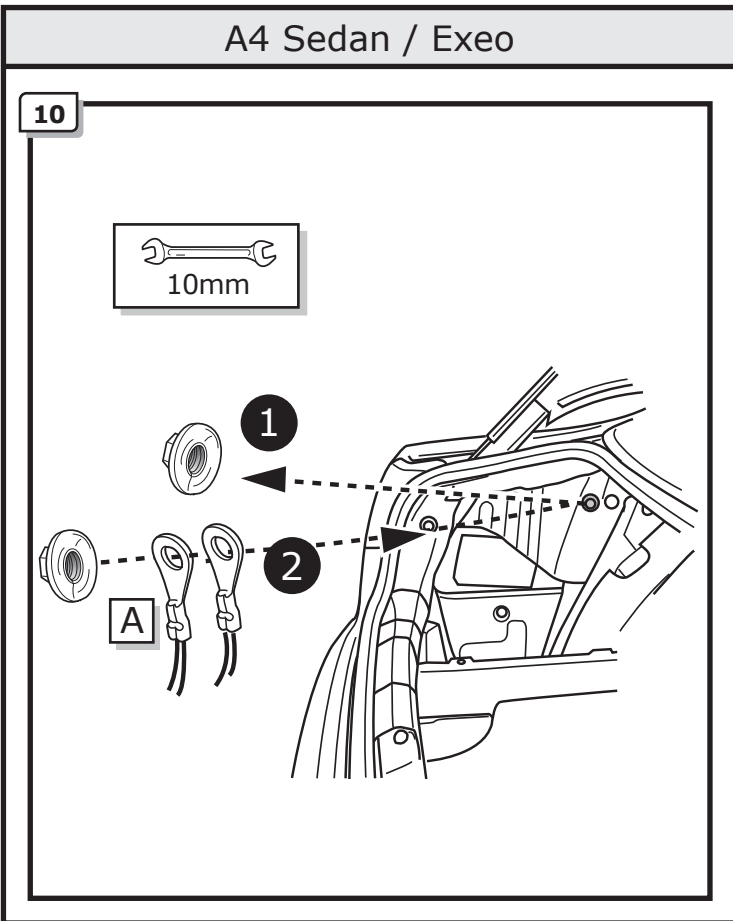
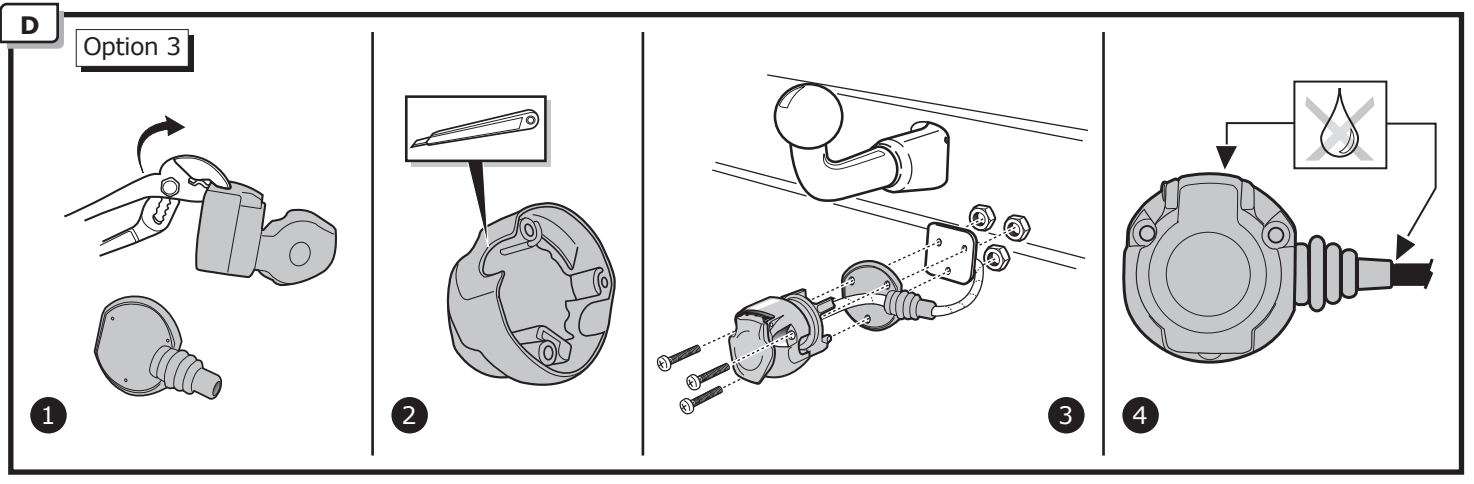
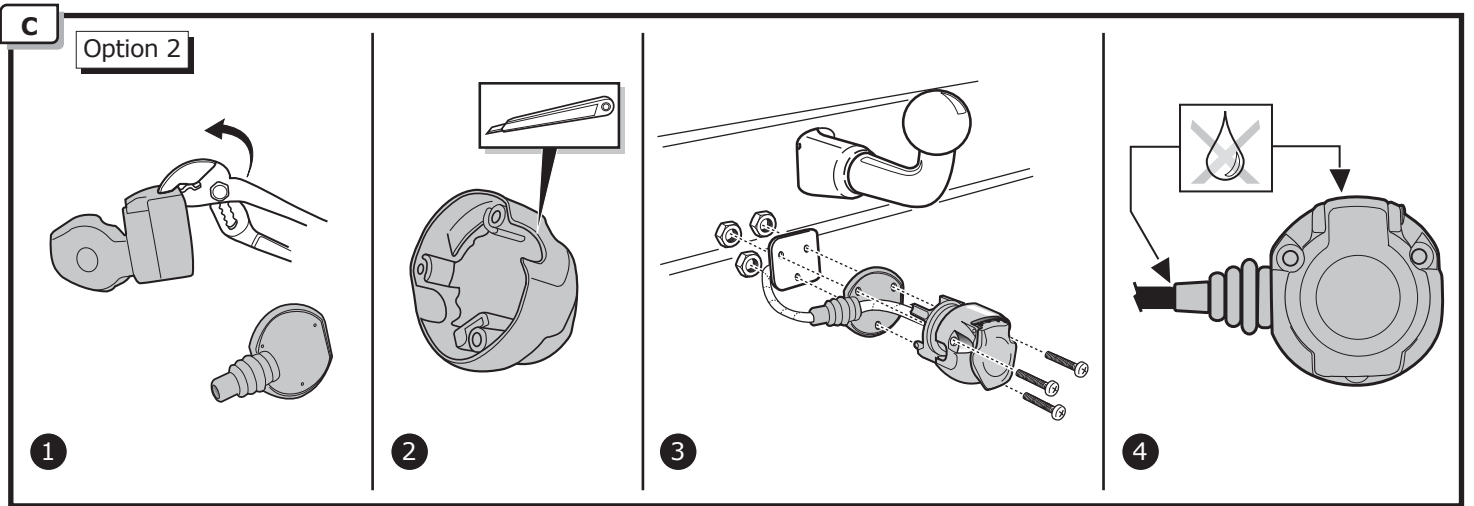

A4 Avant / Exeo ST

12

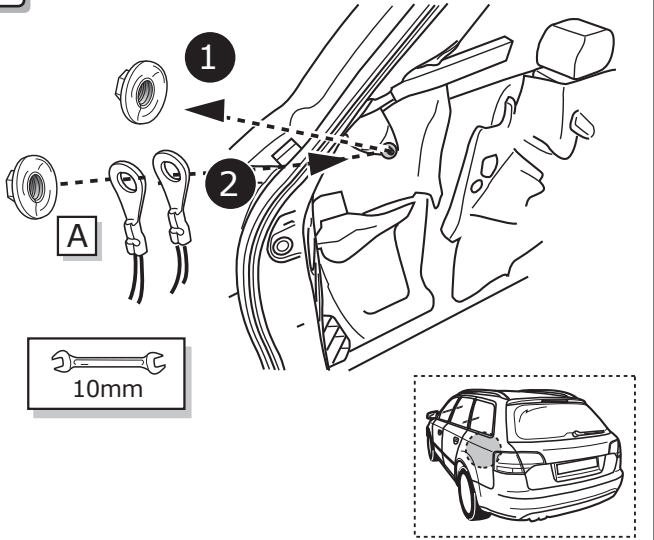

A3 Cabrio

13

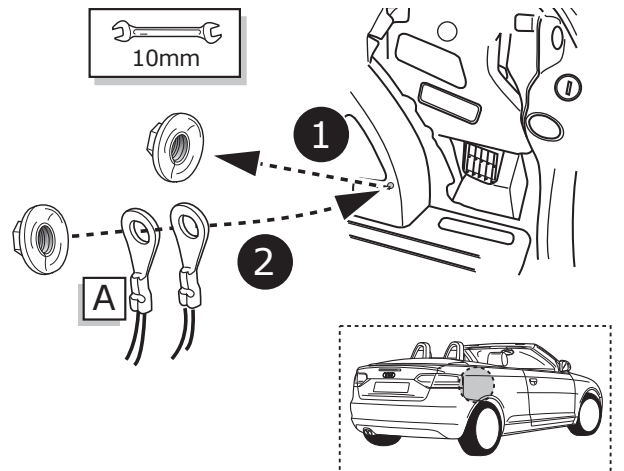

A3

14

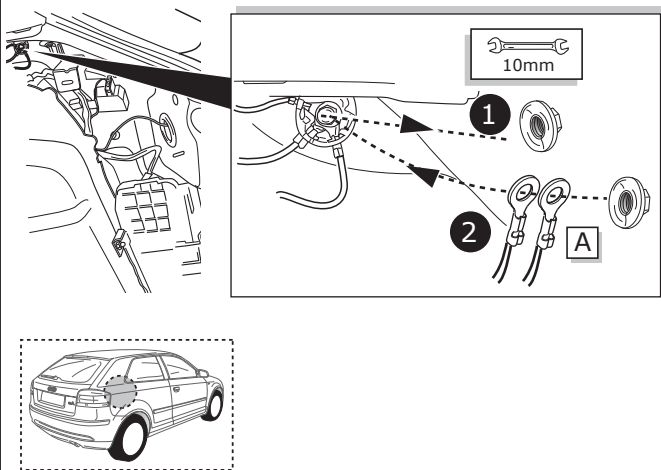

A3 Sportback

15

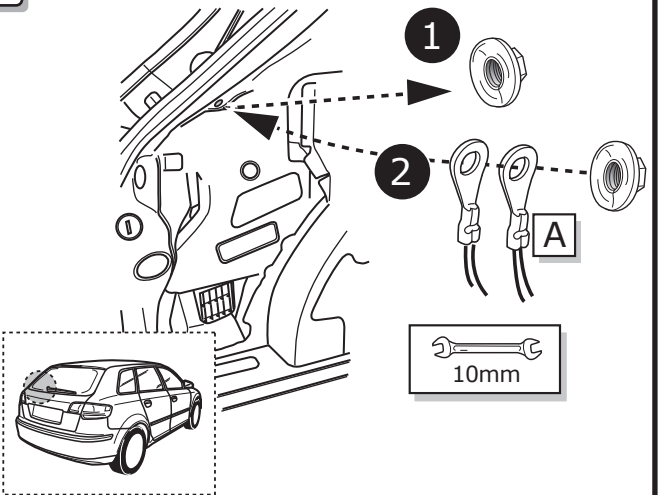

A4 Sedan / A4 Cabrio / A4 Avant / Exeo / Exeo ST

16

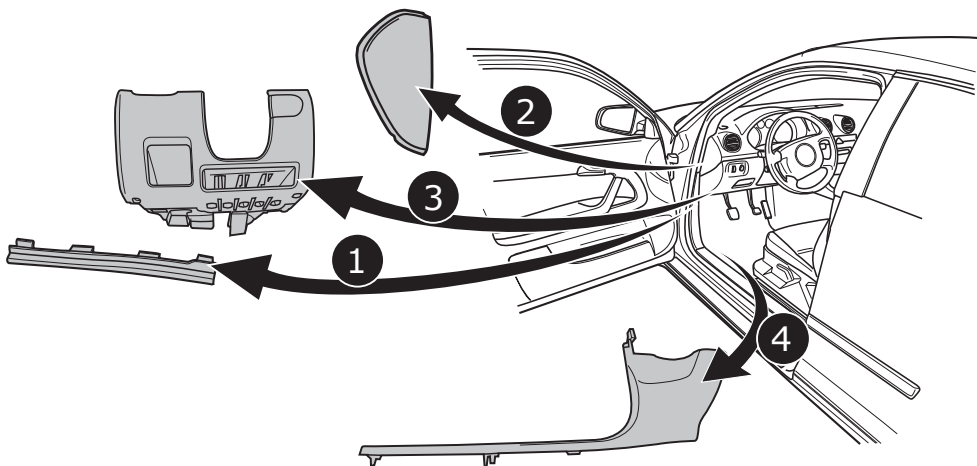

A3 / A3 Sportback / A3 Cabrio

17

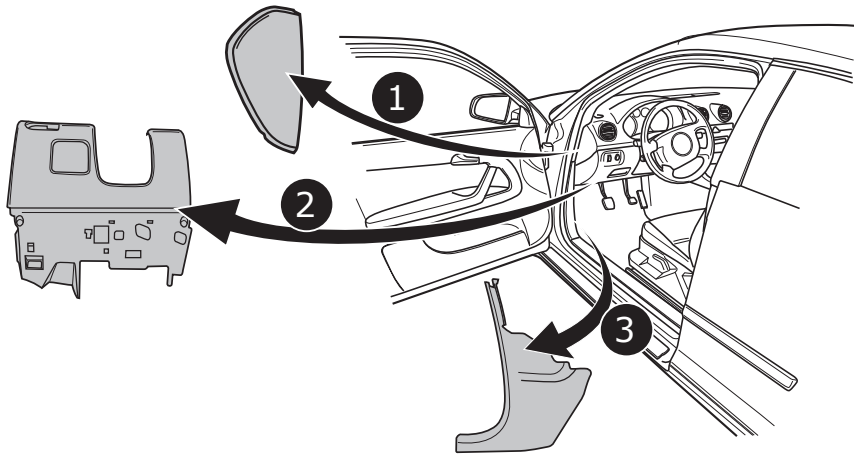

18

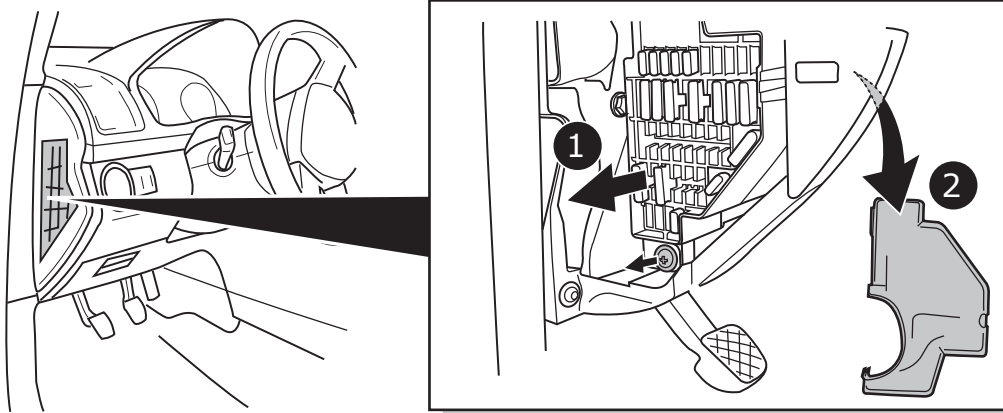

A4 Sedan / A4 Cabrio / A4 Avant / Exeo / Exeo ST

19

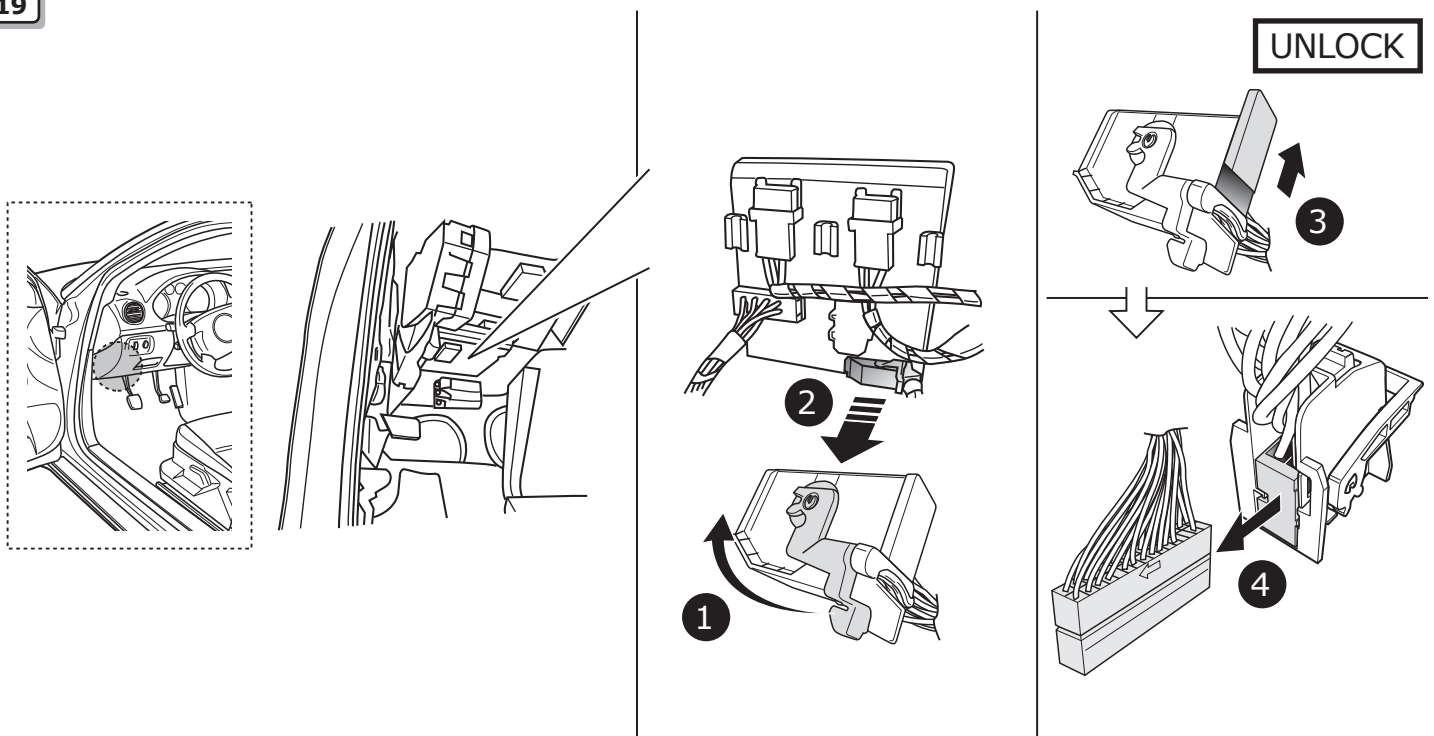

20

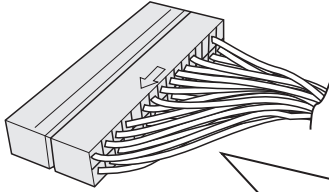

DE	Grün	CZ	Zelená
FR	Vert	DK	Grøn
NL	Groen	FI	Vihreä
GB	Green	GR	Πράσινο
ES	Verde	NO	Grønn
IT	Verde	PL	Zielony
SE	Grön		

DE	Blau/Rot	CZ	Modrá/Červeno
FR	Blue/Rouge	DK	Blå/Rød
NL	Blauw/Rood	FI	Sininen/Punainen
GB	Blue/Red	GR	Μπλε/Κόκκινο
ES	Azul/Rojo	NO	Blå/Rød
IT	Blu/Rosso	PL	Niebieski/Czerwony
SE	Blå/Röd		

DE	Braun	CZ	Hnědá
FR	Marron	DK	Brun
NL	Bruin	FI	Ruskea
GB	Brown	GR	Καφέ
ES	Marrón	NO	Brun
IT	Marrone	PL	Brązowy
SE	Brun		

Can-bus
Datawire

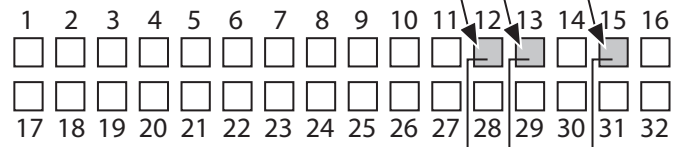

DE	Orange/Braun	CZ	Oranžovo/Hnědá
FR	Orange/Marron	DK	Orange/Brun
NL	Oranje/Bruin	FI	Oranssi/Ruskea
GB	Orange/Brown	GR	Πορτοκαλι/Καφέ
ES	Naranja/Marrón	NO	Oransje/Brun
IT	Arancione/Marrone	PL	Pomarańczowy/Brązowy
SE	Orange/Brun		

DE	Rot/Schwarz	CZ	Červeno/Černá
FR	Rouge/Noir	DK	Rød/Sort
NL	Rood/Zwart	FI	Punainen/Musta
GB	Red/Black	GR	Κόκκινο/Μαύρο
ES	Rojo/Negro	NO	Rød/Svart
IT	Rosso/Nero	PL	Czerwony/Czarny
SE	Röd/Svart		

DE	Orange/Grün	CZ	Oranžovo/Zelená
FR	Orange/Vert	DK	Orange/Grøn
NL	Oranje/Groen	FI	Oranssi/Vihreä
GB	Orange/Green	GR	Πορτοκαλι/Πράσινο
ES	Naranja/Verde	NO	Oransje/Grønn
IT	Arancione/Verde	PL	Pomarańczowy/Zielony
SE	Orange/Grön		

DE	Orange/Braun	CZ	Oranžovo/Hnědá
FR	Orange/Marron	DK	Orange/Brun
NL	Oranje/Bruin	FI	Oranssi/Ruskea
GB	Orange/Brown	GR	Πορτοκαλι/Καφέ
ES	Naranja/Marrón	NO	Oransje/Brun
IT	Arancione/Marrone	PL	Pomarańczowy/Brązowy
SE	Orange/Brun		

Pos. 1

DE	Braun	CZ	Hnědá
FR	Marron	DK	Brun
NL	Bruin	FI	Ruskea
GB	Brown	GR	Καφέ
ES	Marrón	NO	Brun
IT	Marrone	PL	Brązowy
SE	Brun		

Pos. 1

DE	Orange/Grün	CZ	Oranžovo/Zelená
FR	Orange/Vert	DK	Orange/Grøn
NL	Oranje/Groen	FI	Oranssi/Vihreä
GB	Orange/Green	GR	Πορτοκαλι/Πράσινο
ES	Naranja/Verde	NO	Oransje/Grønn
IT	Arancione/Verde	PL	Pomarańczowy/Zielony
SE	Orange/Grön		

Pos. 2

DE	Grün	CZ	Zelená
FR	Vert	DK	Grøn
NL	Groen	FI	Vihreä
GB	Green	GR	Πράσινο
ES	Verde	NO	Grønn
IT	Verde	PL	Zielony
SE	Grön		

DE	Rot/Schwarz	CZ	Červeno/Černá
FR	Rouge/Noir	DK	Rød/Sort
NL	Rood/Zwart	FI	Punainen/Musta
GB	Red/Black	GR	Κόκκινο/Μαύρο
ES	Rojo/Negro	NO	Rød/Svart
IT	Rosso/Nero	PL	Czerwony/Czarny
SE	Röd/Svart		

Pos. 3

DE	Blau/Rot	CZ	Modrá/Červeno
FR	Blue/Rouge	DK	Blå/Rød
NL	Blauw/Rood	FI	Sininen/Punainen
GB	Blue/Red	GR	Μπλε/Κόκκινο
ES	Azul/Rojo	NO	Blå/Rød
IT	Blu/Rosso	PL	Niebieski/Czerwony
SE	Blå/Röd		

Pos. 3

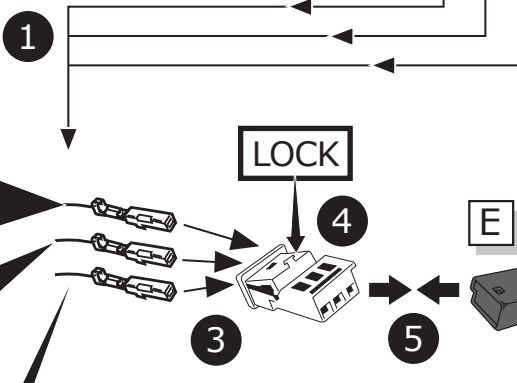

21

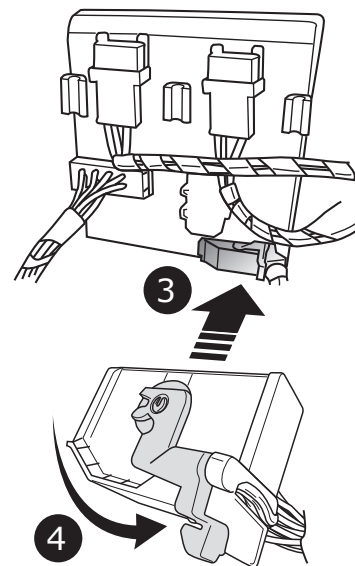
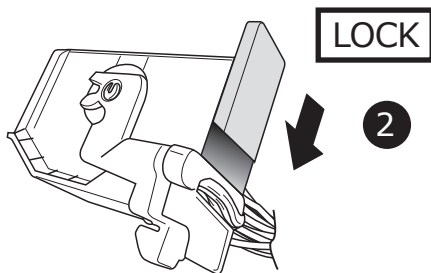
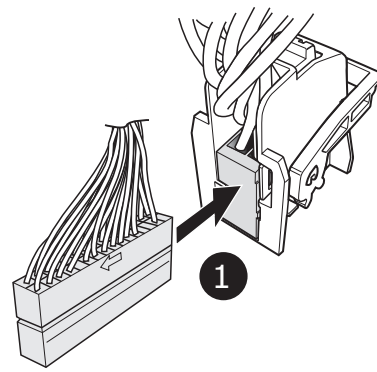
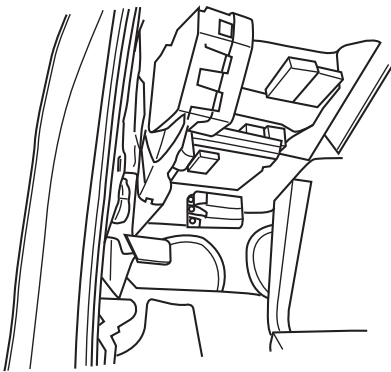
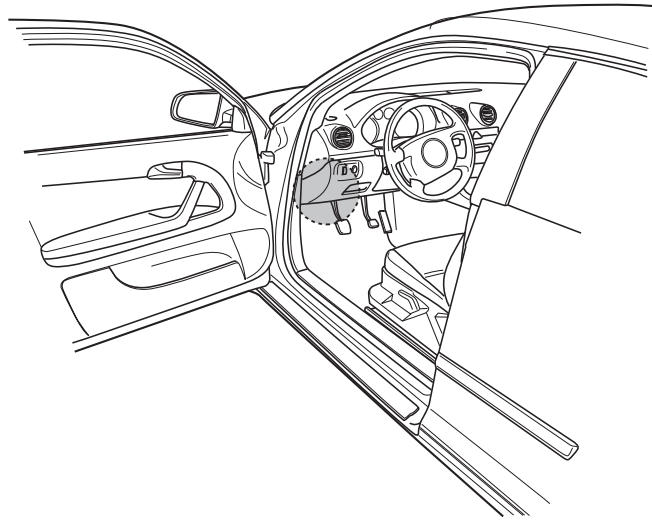

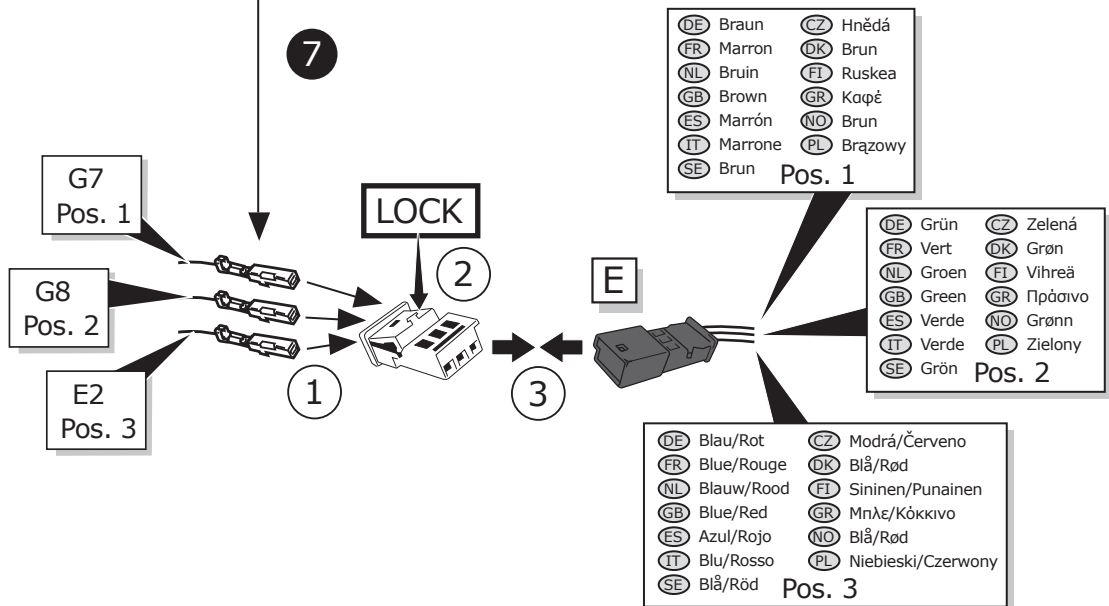
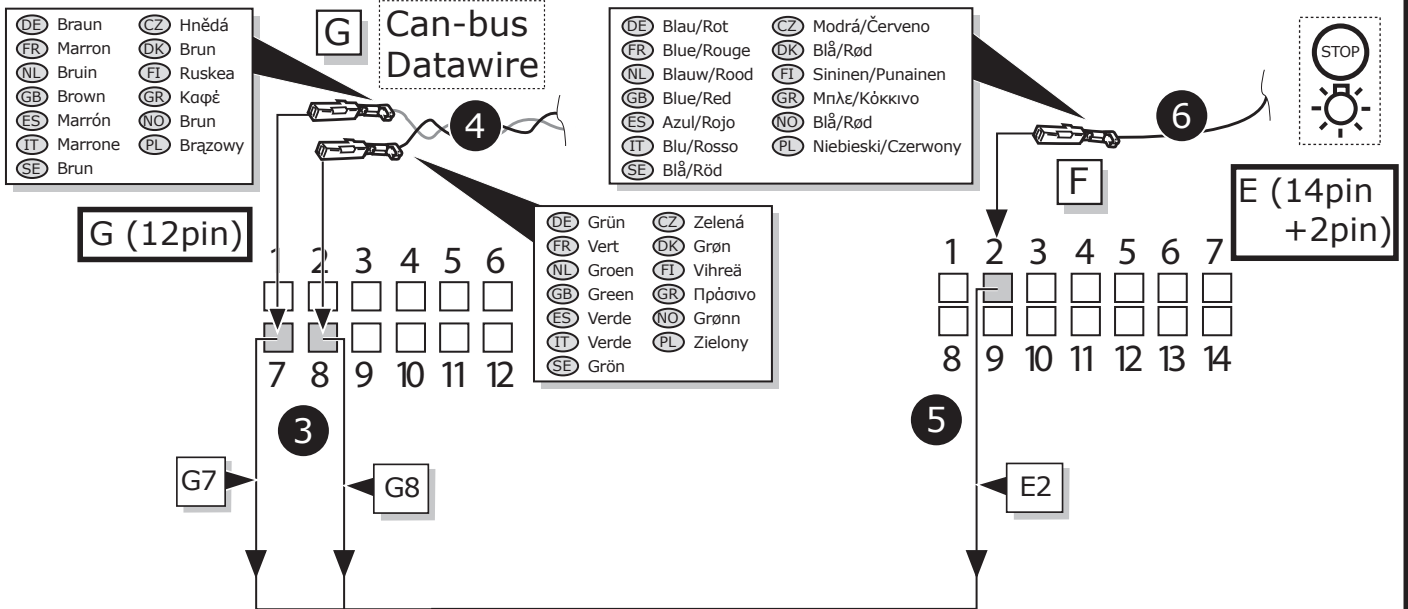
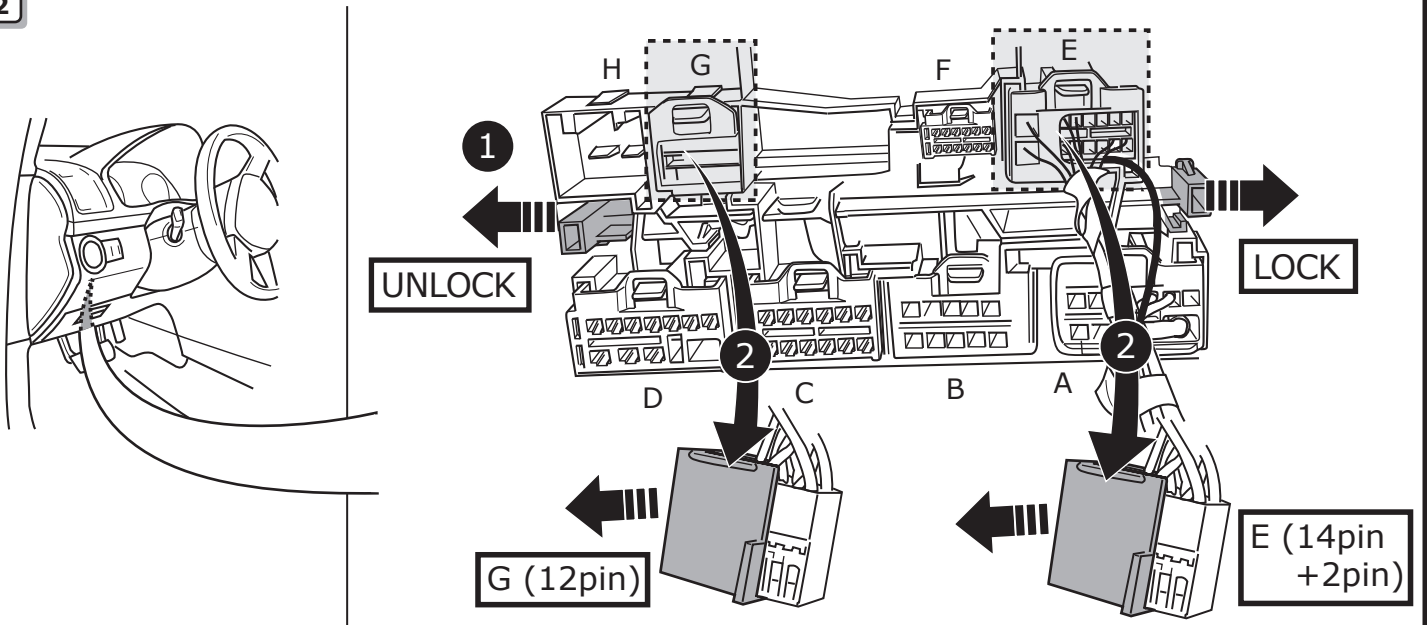

23

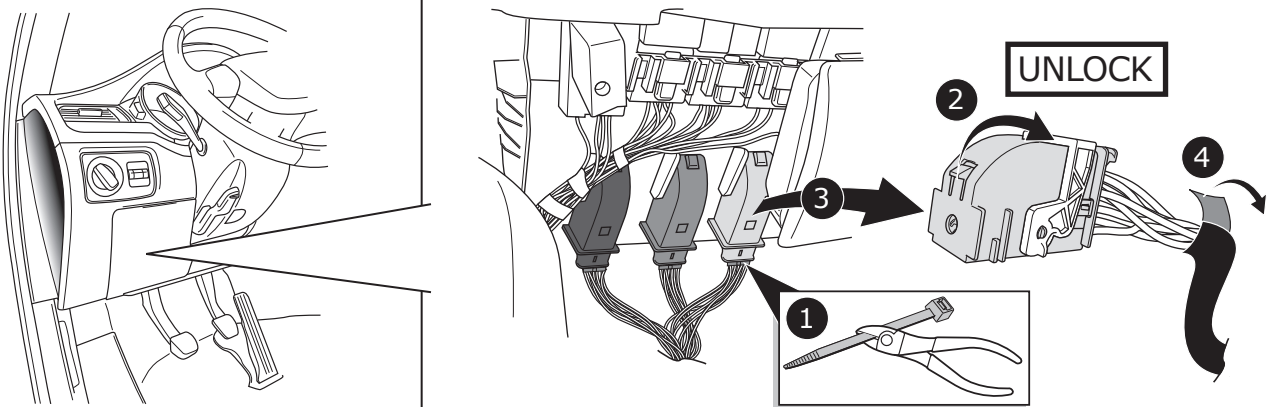

24

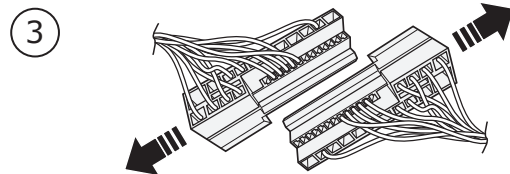
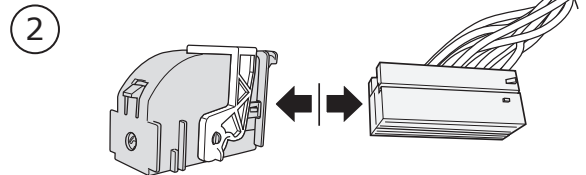
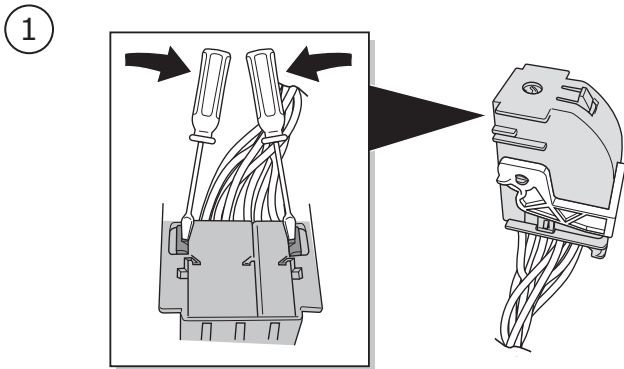

25

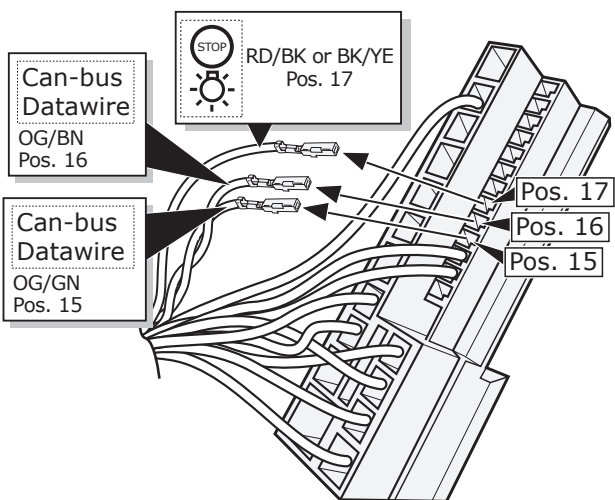

26

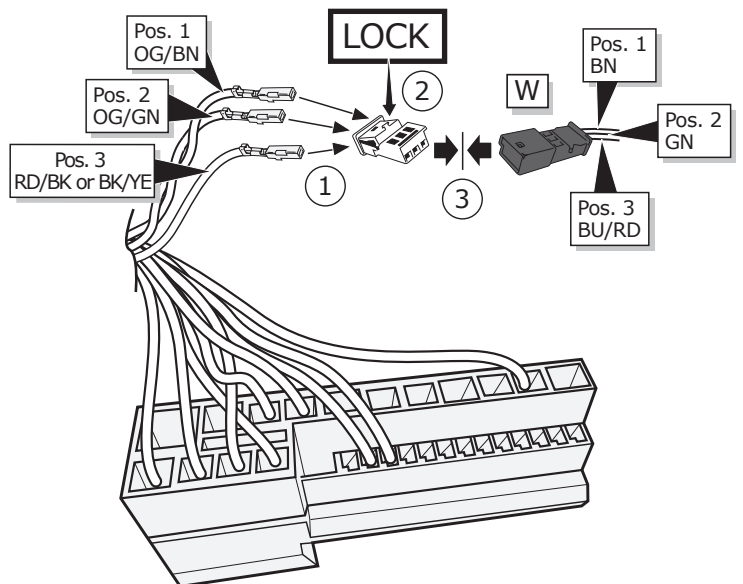

27

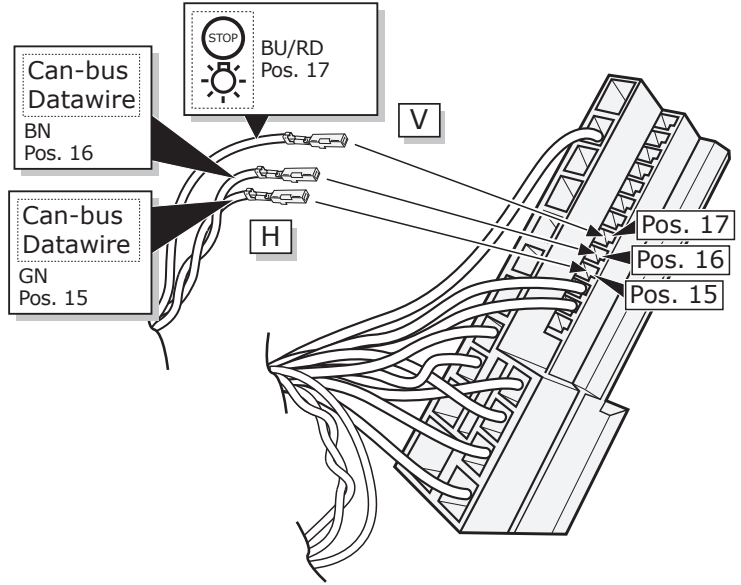

28

1

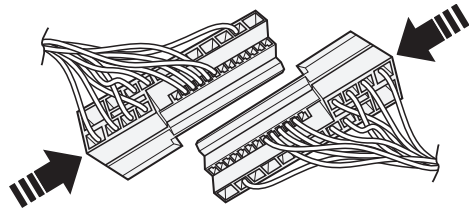

2

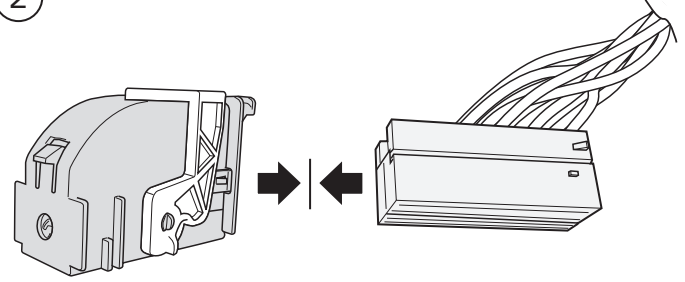

29

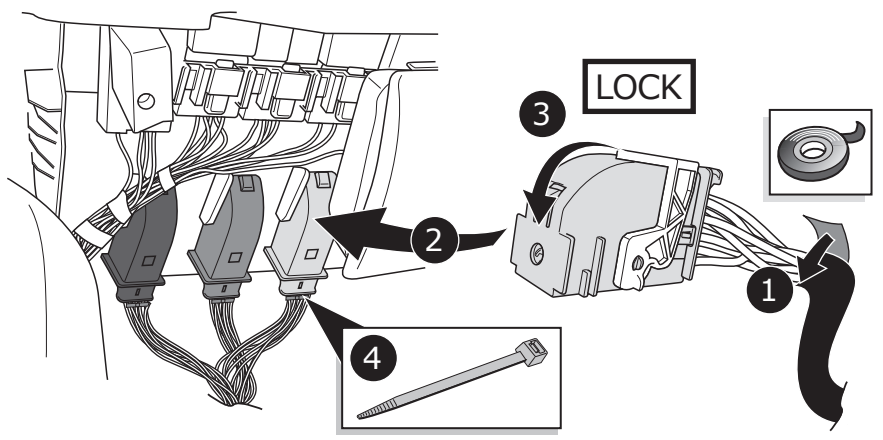
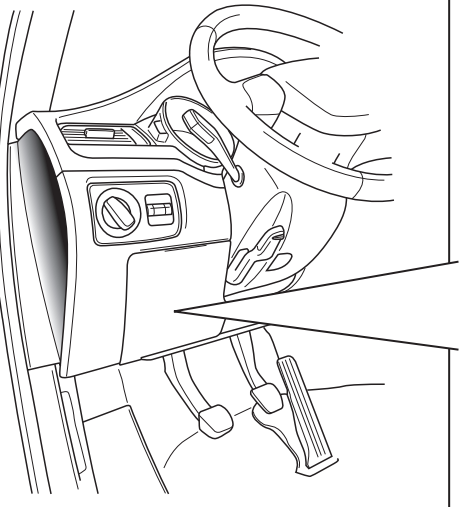

OPTION 1

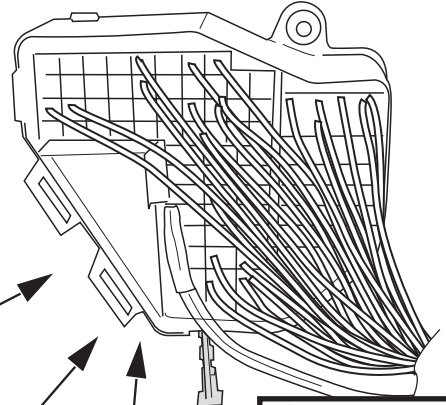
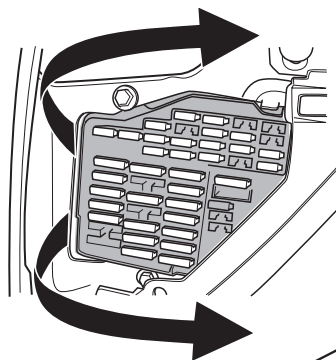
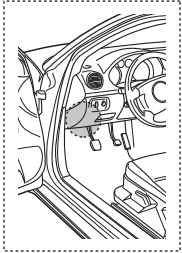

1 UNLOCK
3 LOCK

+15 **15 Amp.**

DE Gelb	CZ Žlutá
FR Jaune	DK Gul
NL Geel	FI Keltainen
GB Yellow	GR Κίτρινο
ES Amarillo	NO Gul
IT Giallo	PL Żółty
SE Gul	

+30 **15 Amp.**

DE Rot	CZ Červená
FR Rouge	DK Rød
NL Rood	FI Punainen
GB Red	GR Κόκκινο
ES Rojo	NO Rød
IT Rosso	PL Czerwony
SE Röd	

+30 **20 Amp.**

DE Orange	CZ Oranžová
FR Orange	DK Orange
NL Oranje	FI Oranssi
GB Orange	GR Πορτοκαλί
ES Naranja	NO Oransje
IT Arancione	PL Pomarańczowy
SE Orange	

D

DE Pos. frei	CZ Pos. více
FR Pos. libre	DK Pos. tomme
NL Pos. free	FI Pos. vapaana
GB Pos. vrij	GR Pos. θέσις
ES Pos. libre	NO Pos. ledig
IT Pos. libero	PL Pos. opcji
SE Pos. fri	

If necessary **+15**

31

OPTION 2

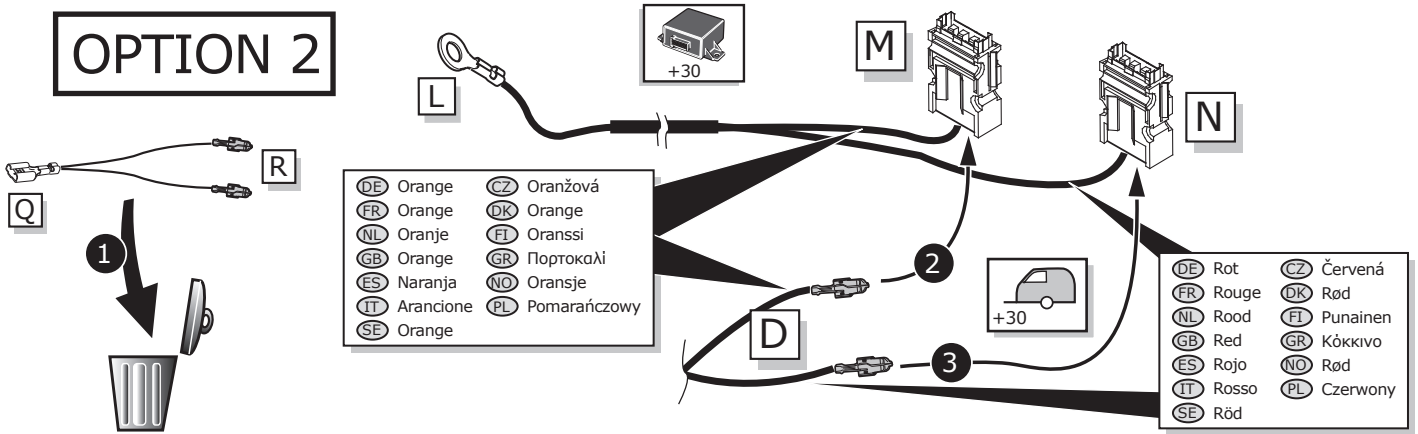

32

OPTION 2

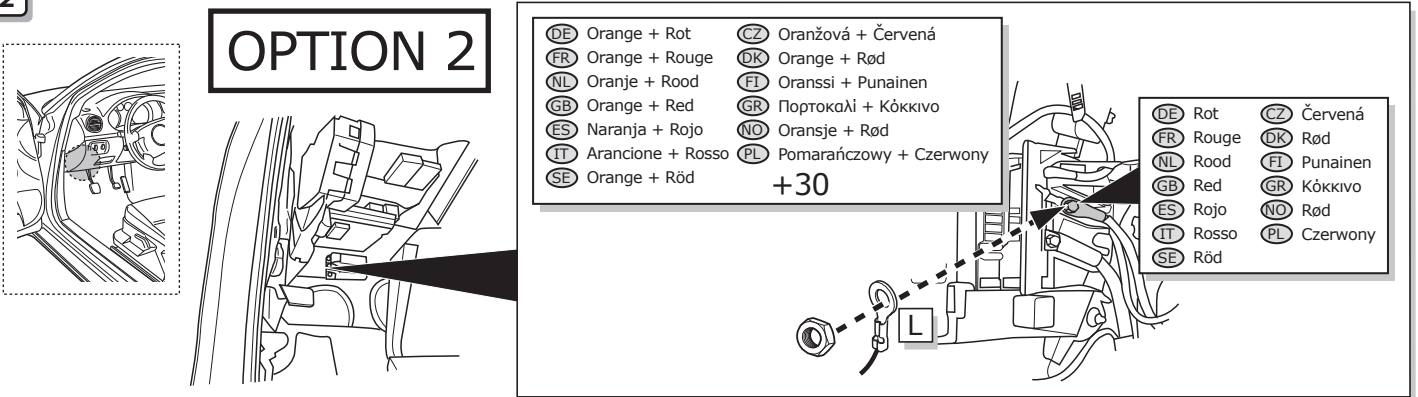

33

OPTION 2

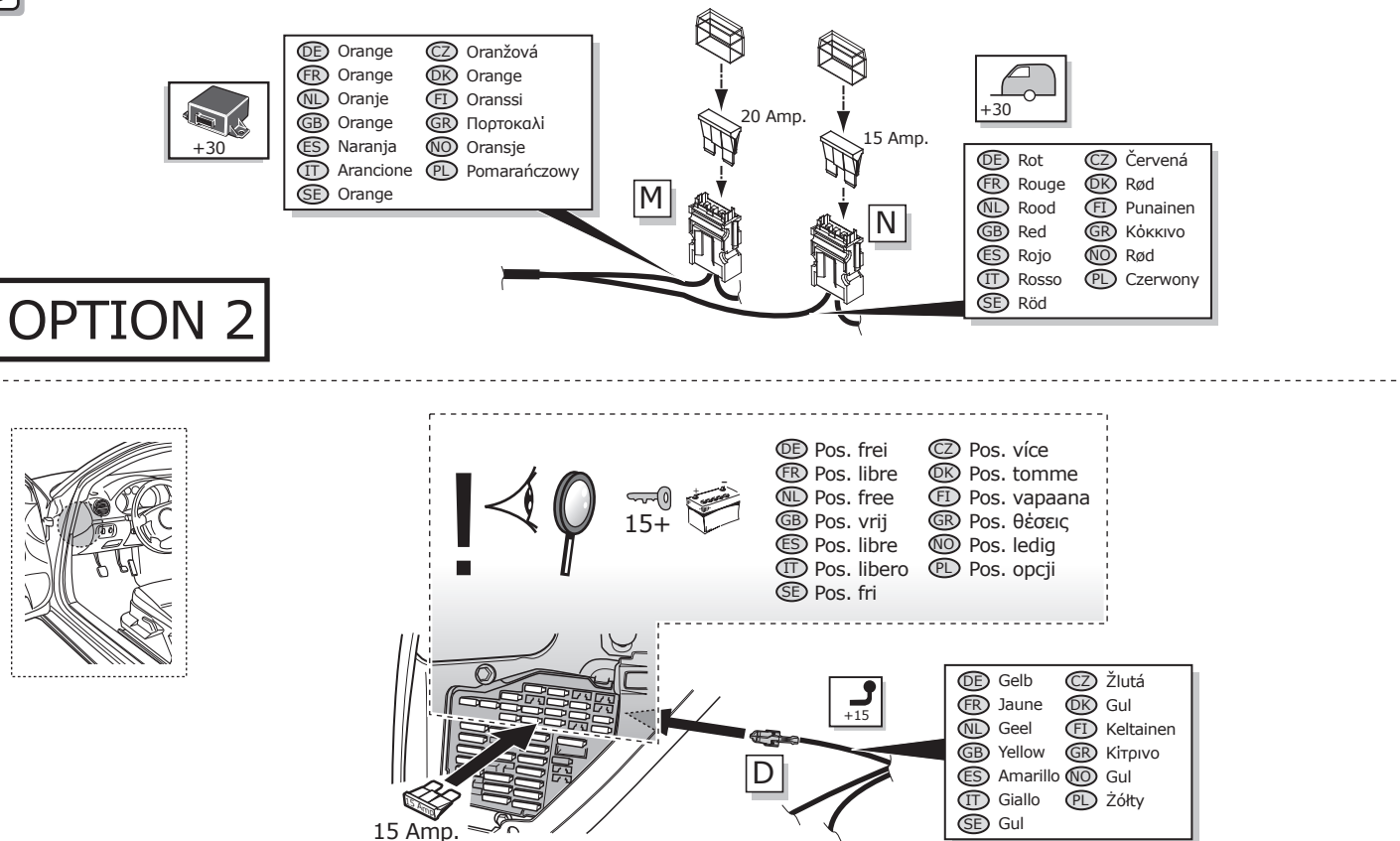

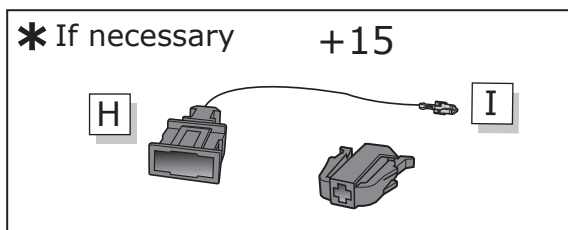
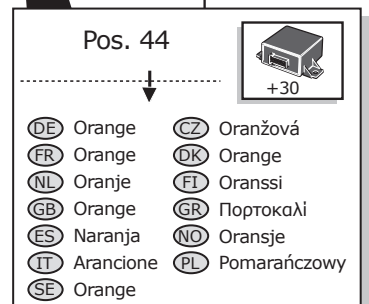
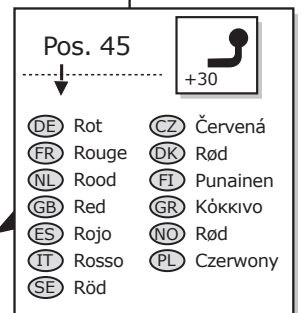
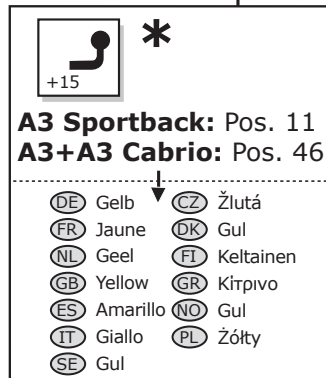
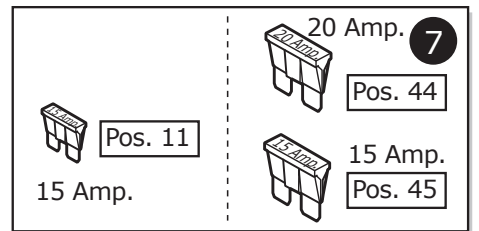
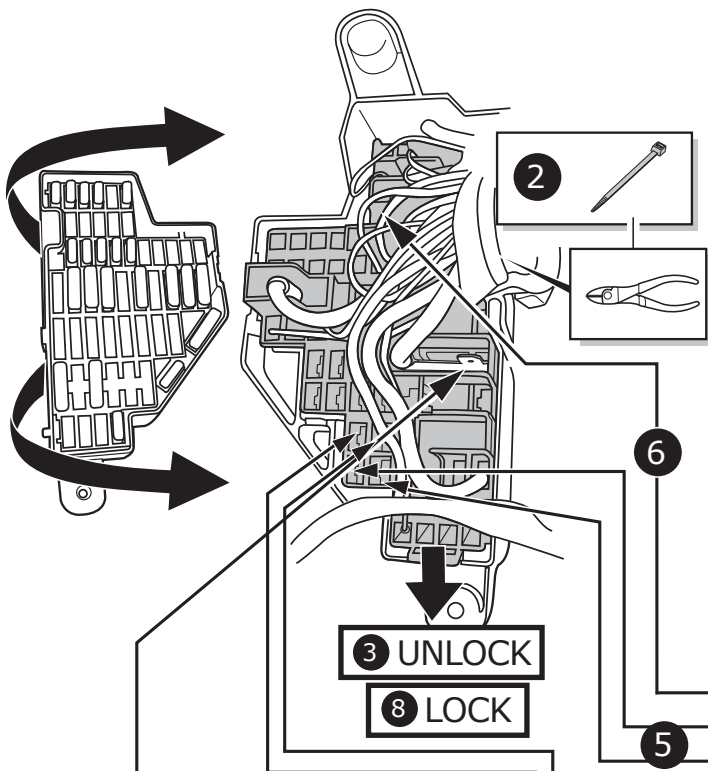
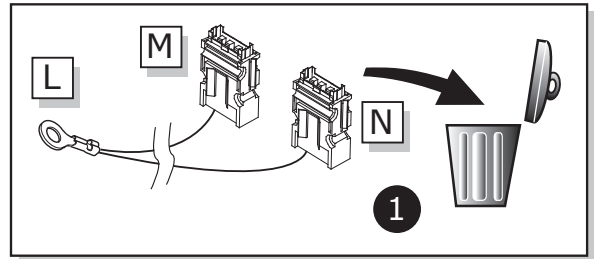
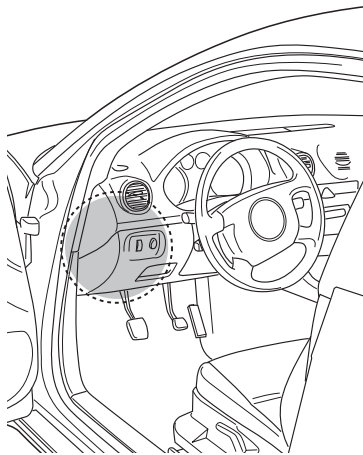

35

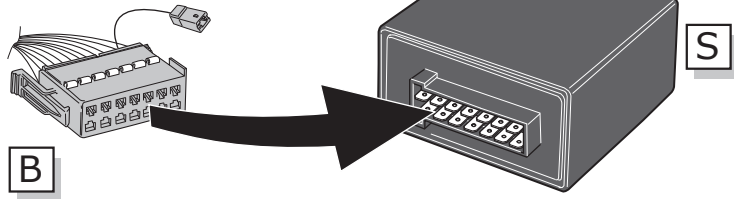
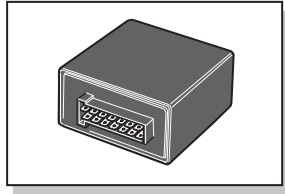

36

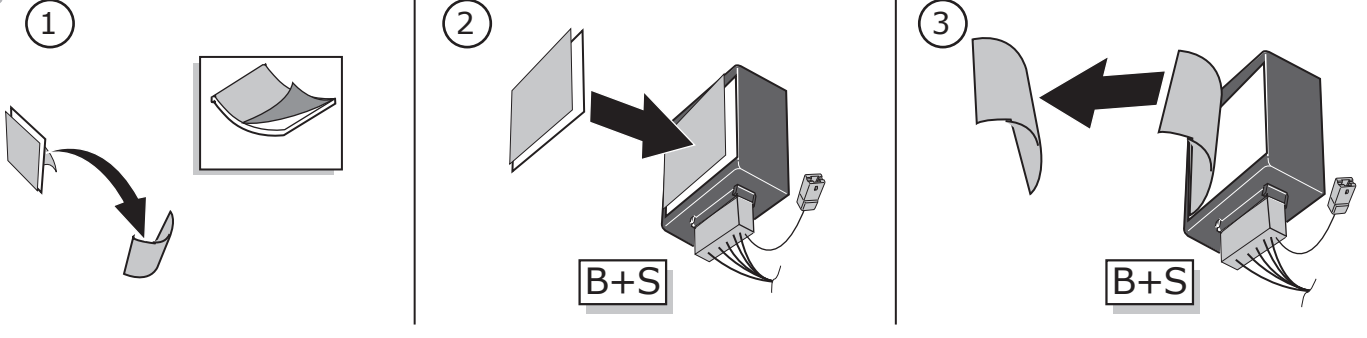

A4 Sedan / Exeo

37

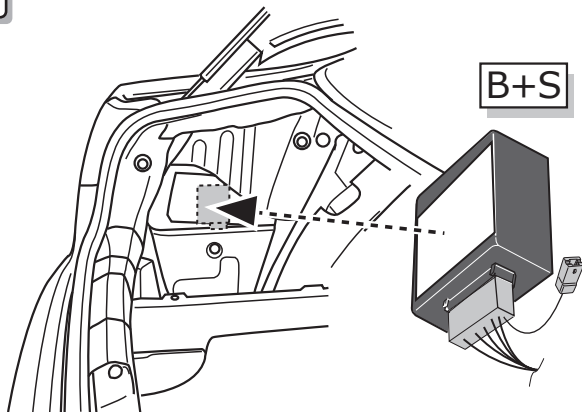

A4 Cabrio

38

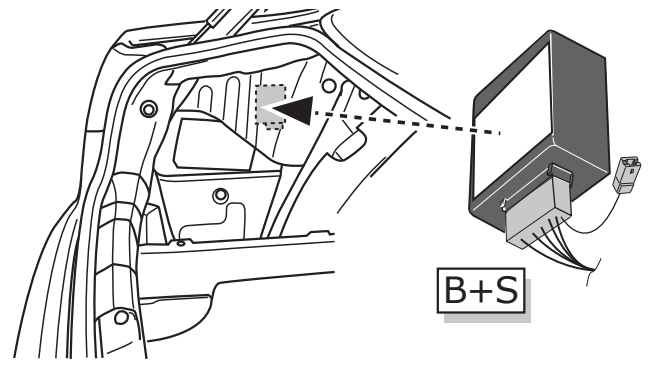

A4 Avant / Exeo ST

39

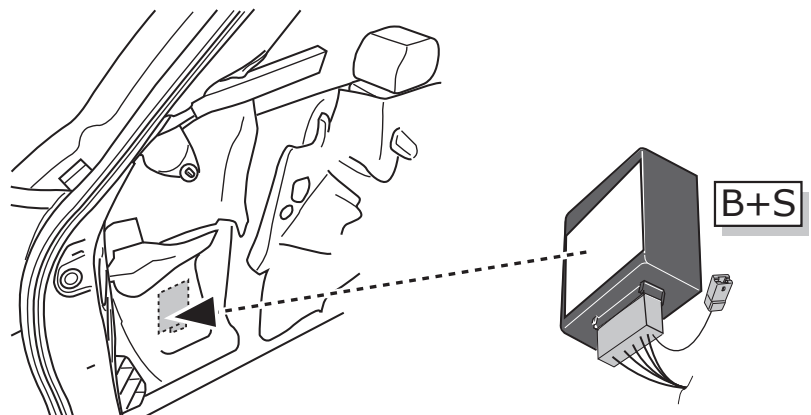
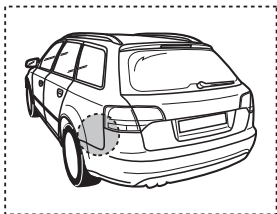

A3

40

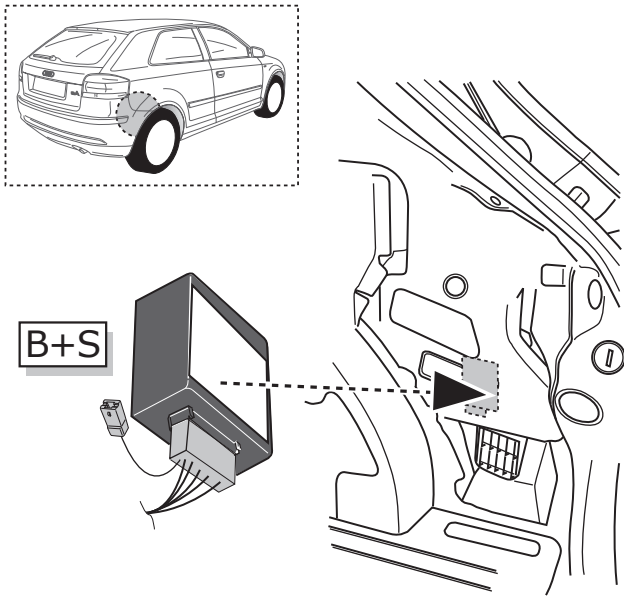

A3 Sportback

41

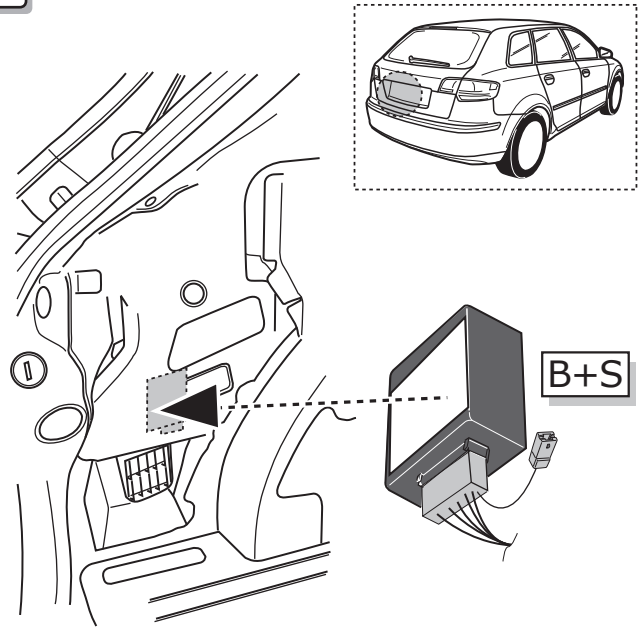

A3 Cabrio

42

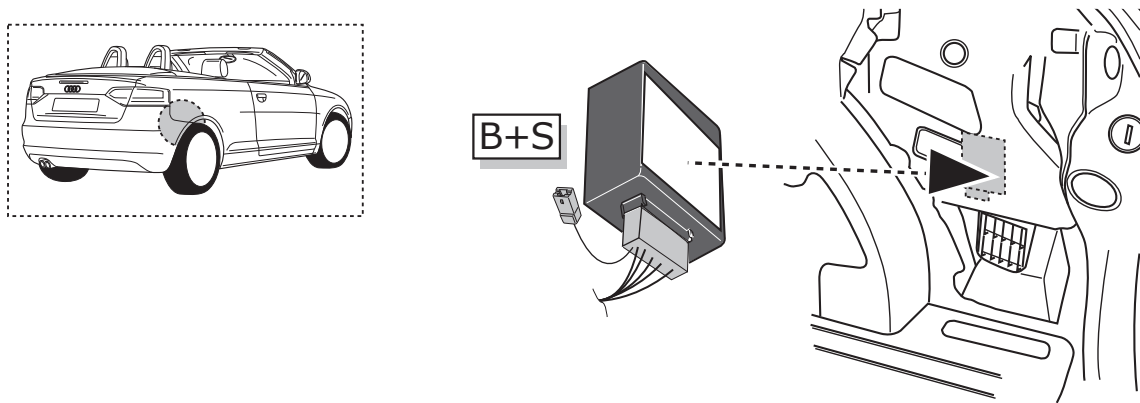

A4 Sedan / A4 Cabrio / A4 Avant / A3 / A3 Cabrio / A3 Sportback / Exeo / Exeo ST

43

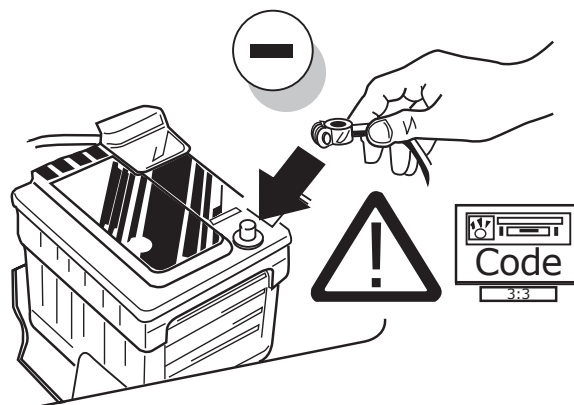

44

- (DE) Das fahrzeugseitige Gateway muss von einem VW-Händler mit einem VAG-Service-Tester zur Funktionserweiterung Anhängervorrichtung codiert werden.
- (FR) La porte du reseau multiplexé du véhicule doit être télécodé par un concession VW/Audi avec la valise VAG, pour ajouter la fonction dispositif d'attelage.
- (NL) De gateway van het voertuig moet met een VAG-Service-Tester voor functie-uitbreiding van de trekhaak via zelf diagnose bij de dealer worden gecodeerd.
- (GB) A VAG Service Tester must be used to code the vehicle's Gateway at self diagnosis with the additional function for the towing hitch at the dealer.
- (ES) Para controlar el funcionamiento del enganche es necesario controlar el gateway del vehículo con un VAG-Service-Tester en el concesionario.
- (IT) Per l'ampliamento funzionale del gancio di traino, il gateway del veicolo deve essere codificato tramite un tester del servizio assistenza VAG.
- (SE) Fordonets inkörsport måste kodas av återförsäljaren med en VAG testutrustning för att dragkroken skall fungera korrekt.
- (CZ) Komunikační brána vozidla musí být zakódována prodejcem pomocí servisní zkoušečky VAG pro rozšíření funkce tažného háku.
- (DK) Vognens datastik skal kodes af forhandleren med en VAG-servicetester for udvidelse af funktionen til også at gælde trækroge.
- (FI) Jälleenmyyjän pitää antaa ajoneuvon väylälle VAG-testilaitteella koodi vetokoukkutoimintoa varten.
- (GR) Η πύλη του οχήματος θα πρέπει να κωδικοποιηθεί από τον έμπορο με έναν Ελεγκτή Υπηρεσίας VAG για επέκτασης της λειτουργίας του άγκιστρου ρυμούλκησης.
- (NO) Kjøretøyets router må dekoderes med en VAG-servicetester hos forhandleren, for å legge til nye funksjoner til tilhengerfestet.
- (PL) Centrala (gateway) sieci pojazdu musi zostać zakodowana u dealera samochodowego za pomocą testera diagnostycznego VAG w celu rozbudowania funkcji haka holowniczego.

45

- | | |
|--|--|
| <ul style="list-style-type: none"> (DE) FUNKTIONEN KONTROLLIEREN MIT EINEM PRÜFGERÄT MIT WIDERSTAND ODER MIT LEUCHTEN MIT DER GENAUEN WATTZAHL! (FR) CONTRÔLER LES FONCTIONS AVEC UNE BOÎTE DE TEST AVEC DE LA CHARGE OU DES LAMPES AVEC LA QUANTITÉ CORRECTE DE WATT! (NL) CONTROLEER FUNCTIES MET EEN TESTER MET BELASTING OF LAMPEN MET DE JUISTE WATTAGE! (GB) TEST ALL CIRCUIT FUNCTIONS WITH A TESTBOX WITH THE CORRECT POWER LOAD FOR EACH UNIT. A TESTBOX ON WHICH ONLY LEDs ARE USED CAN NOT BE USED IN THIS CASE (ES) ¡CONTROLAR FUNCIONES CON UN TESTER CON CARGA O LUCES CON EL CORRECTO WATTAJE! (IT) CONTROLLA FUNZIONI CON UN TESTER CON CARICO O LAMPADE DEL GIUSTO WATT-TAGGIO! | <ul style="list-style-type: none"> (SE) KONTROLLERA FUNKTIONERNA MED EN TESTARE MED BELASTNING ELLER LAMPOR MED RÄTT WATT-VÄRDE! (CZ) OVĚŘTE FUNKCE POMOČÍ TESTOVACÍHO BOXU NEBO SVĚTEL S PŘÍSLUŠNÝM VÝKONEM! (DK) CHECK FUNKTIONERNE MED EN TESTBOKS, MED BELASTNING ELLER MED LYGTER MED DET KORREKTE ANTAL WATT! (FI) TARKISTA TOIMINNOT KÄYTTÄMÄLLÄ TESTILAITE, JOSSA ON OIKEATEHOINEN KUORMITUS TAI OIKEATEHOISET LAMPUT! (GR) ΕΛΕΓΞΤΕ ΤΙΣ ΛΕΙΤΟΥΡΓΙΕΣ ΜΕ ΈΝΑ ΚΙΒΩΤΙΟ ΔΟΚΙΜΗΣ ΜΕ ΦΟΡΤΙΟ Ή ΛΑΜΠΗΡΕΣ ΣΩΣΤΗΣ ΠΟΣΟΤΗΤΑΣ ΒΑΤ! (NO) KONTROLLER FUNKSJONENE MED EN TESTER MED BELASTNING ELLER LYSPÆRER MED RIKTIG WATTVERDI! (PL) SPRAWDŹ FUNKCJE UŻYWAJĄC SKRZYŃKI TESTOWEJ Z OBCIĄŻENIEM LUB PODŁĄCZONYMI ŻARÓWKAMI O ODPOWIEDNIEJ MOCY! |
|--|--|

INFO

- | | |
|----------------------------------|--------------------------------------|
| (DE) Einzelteile wieder einbauen | (CZ) Znovu zasuňte obložení |
| (FR) Montez les part enlèves | (DK) Påsæt beklædningen |
| (NL) Terug plaatsen onderdelen | (FI) Asenna verhoilut takaisin |
| (GB) Reinstall linings | (GR) Τοποθετήστε ξανά τις επενδύσεις |
| (ES) Reinstalar componentes | (NO) Sett tilbake deler |
| (IT) Rimetti a posto componenti | (PL) Założyć wykładzinę |
| (SE) Sätt tillbaka delar | |

46

- DE Gebrauchsanleitung.
- FR Mode d'emploi.
- NL Gebruikershandleiding.
- GB User guide.
- ES Guía del usuario.
- IT Manuale di istruzioni.
- SE Bruksanvisning.
- CZ Uživatelská příručka.
- DK Brugervejledning.
- FI Käyttöohjeet.
- GR Οδηγός χρήστη.
- NO Brukerveiledning.
- PL Instrukcja obsługi.

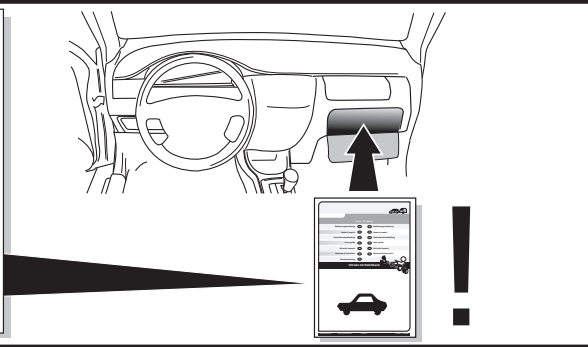

00800
CALL2ECS
22 55 23 27

09.00 - 18.00
Monday - Friday

www.ecs-electronics.nl

(DE) Anschluss Steckdose
 (FR) Connection de la prise
 (NL) Contactdoos aansluiting
 (GB) Socket connection

(ES) Conexión de la caja de enchufe
 (IT) Allaccio zoccolo
 (SE) Anslutning kontaktdosa

(CZ) Objímkový konektor
 (DK) Stikdåse forbindelse
 (FI) Pistorasia liitäntä

(GR) Υποδοχή σύνδεσης
 (NO) Tilkobling koblingsboks
 (PL) Połączenie przez gniazdo

DIN/ISO 11446			1-8															
Pmax	1/L	2	3/31	4/R	5/58-R	6/54	7/58-L	8	9	10	11	12	13					
	21W	21W	21W	21W	42W	3x21W	42W	21W	180W/15Amp.	180W/15Amp.	180W/15Amp.							
(DE)	Schwarz/ Weiß	Blau	Braun	Schwarz/ Grün	Grau/ Rot	Schwarz/ Rot	Grau/ Schwarz	Schwarz	Rot	Gelb	Braun	-	Braun					
(FR)	Noir/ Blanc	Bleu	Marron	Noir/ Vert	Gris/ Rouge	Noir/ Rouge	Gris/ Noir	Noir	Rouge	Jaune	Marron	-	Marron					
(NL)	Zwart/ Wit	Blauw	Bruin	Zwart/ Groen	Grijs/ Rood	Zwart/ Rood	Grijs/ Zwart	Zwart	Rood	Geel	Bruin	-	Bruin					
(GB)	Black/ White	Blue	Brown	Black/ Green	Grey/ Red	Black/ Red	Grey/ Black	Black	Red	Yellow	Brown	-	Brown					
(ES)	Negro/ Blanco	Azul	Marrón	Negro/ Verde	Gris/ Rojo	Negro/ Rojo	Gris/ Negro	Negro	Rojo	Amarillo	Marrón	-	Marrón					
(IT)	Nero/ Bianco	Blu	Marrone	Nero/ Verde	Grigio/ Rosso	Nero/ Rosso	Grigio/ Nero	Nero	Rosso	Giallo	Marrone	-	Marrone					
(SE)	Svart/ Vit	Blå	Brun	Svart/ Grön	Grå/ Röd	Svart/ Röd	Grå/ Svart	Svart	Röd	Gul	Brun	-	Brun					
(CZ)	Černo/ Bílá	Modrá	Hnědá	Černo/ Zelená	Šedo/ Červená	Černo/ Červená	Šedo/ Černá	Černá	Červená	Žlutá	Hnědá	-	Hnědá					
(DK)	Sort/ Hvid	Blå	Brun	Sort/ Grøn	Grå/ Rød	Sort/ Rød	Grå/ Sort	Sort	Rød	Gul	Brun	-	Brun					
(FI)	Musta/ Valkoinen	Sininen	Ruskea	Musta/ Vihreä	Harmaa/ Punainen	Musta/ Punainen	Harmaa/ Musta	Musta	Punainen	Keltainen	Ruskea	-	Ruskea					
(GR)	Μαύρο/ Λευκό	Μπλε	Καφέ	Μαύρο/ Πράσινο	Γκρι/ Κόκκινο	Μαύρο/ Κόκκινο	Γκρι/ Μαύρο	Μαύρο	Κόκκινο	Κίτρινο	Καφέ	-	Καφέ					
(NO)	Svart/ Hvit	Blå	Brun	Svart/ Grønn	Grå/ Rød	Svart/ Rød	Grå/ Svart	Svart	Rød	Gul	Brun	-	Brun					
(PL)	Czarny/ Biały	Niebieski	Brązowy	Czarny/ Zielony	Szary/ Czerwony	Czarny/ Czerwony	Szary/ Czarny	Czarny	Czerwony	Żółty	Brązowy	-	Brązowy					